



REXTON[®]

Electrifying lifestyle !



**DATA CABINETS
&
MODULAR ENCLOSURES**

Wall Cabinets

Features & Benefits

- Lockable, aesthetic glass door with quick release hinges for easy removal.
- Door can be hinged left or right.
- Lockable & removable side panels.
- Fast easy installation by single operator.
- 4 height variations-400mm, 600mm, 750mm & 900mm.
- 3 depth available-120mm, 150mm, 300mm
- Steel thickness: 1.1mm.
- Available in standard Light Grey & custom colours.

Cabinets

WALL CABINETS

6U CABINETS

RWC6U450



Dimensions	Thickness
360(H) x 450(W) x 450(D)	1.1mm
Accessories	
Power Box PDU	: NA
Glass door with lock	: ✓
Vertical cable manager	: ✓
Metallic Plate (for fixing optical network unit)	: ✓
Fan Tray	: NA
Wheel	: NA
Total Weight	: 15.15kg

RWC6U600



Dimensions	Thickness
360(H) x 600(W) x 600(D)	1.1mm
Accessories	
Power Box PDU	: NA
Glass door with lock	: ✓
Vertical cable manager	: ✓
Metallic Plate (for fixing optical network unit)	: ✓
Fan Tray	: NA
Wheel	: NA
Total Weight	: 17.6kg

RWC6U500



Dimensions	Thickness
360(H) x 600(W) x 500(D)	1.1mm
Accessories	
Power Box PDU	: 6way PDU 13A or 15A 1No.
Glass door with lock	: ✓
Vertical cable manager	: ✓
Metallic Plate (for fixing optical network unit)	: ✓
Fan Tray	: NA
Wheel	: NA
Total Weight	: 16.5kg

6U CABINETS

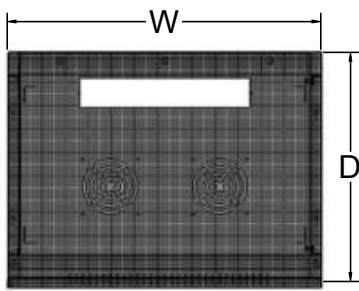

TOP VIEW

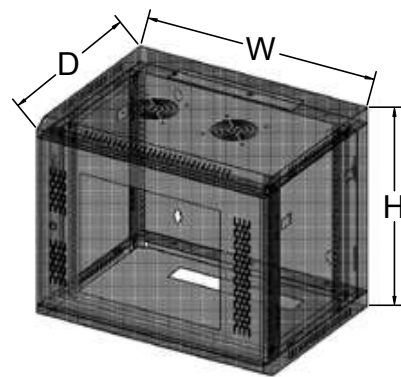

ISOMETRIC VIEW

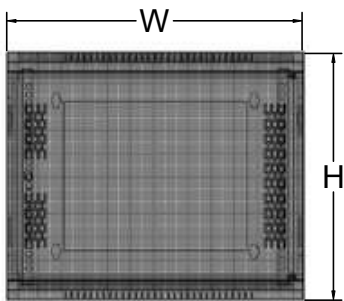

FRONT VIEW

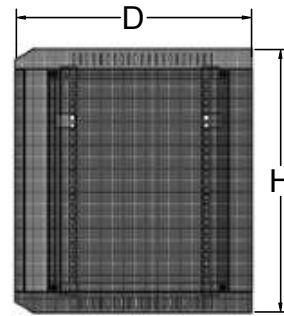

SIDE VIEW

9U CABINETS

RWC9U450



Dimensions	Thickness
500(H) x 450(W) x 450(D)	1.1mm
Accessories	
Power Box PDU	: NA
Glass door with lock	: ✓
Vertical cable manager	: ✓
Metallic Plate (for fixing optical network unit)	: ✓
Fan Tray	: NA
Wheel	: NA
Total Weight	: 17.5kg

RWC9U500



Dimensions	Thickness
500(H) x 600(W) x 500(D)	1.1mm
Accessories	
Power Box PDU	: NA
Glass door with lock	: ✓
Vertical cable manager	: ✓
Metallic Plate (for fixing optical network unit)	: ✓
Fan Tray	: NA
Wheel	: NA
Total Weight	: 18.8kg

RWC9U600



Dimensions	Thickness
500(H) x 600(W) x 600(D)	1.1mm
Accessories	
Power Box PDU	: NA
Glass door with lock	: ✓
Vertical cable manager	: ✓
Metallic Plate (for fixing optical network unit)	: ✓
Fan Tray	: NA
Wheel	: NA
Total Weight	: 20.1kg

9U CABINETS

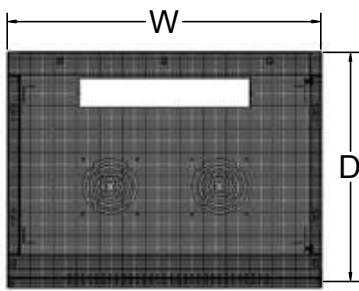

TOP VIEW

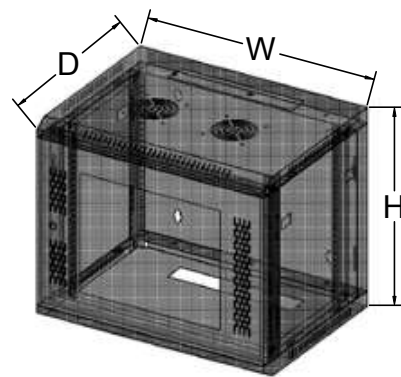

ISOMETRIC VIEW

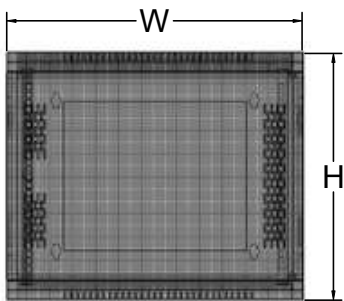

FRONT VIEW

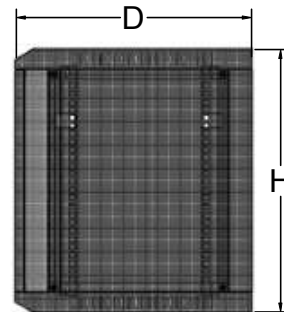

SIDE VIEW

12U CABINETS

RWC12U150



Dimensions	Thickness
600(H) x 600(W) x 150(D)	1.1mm
Accessories	
Power Box PDU	: NA
Glass door with lock	: ✓
Vertical cable manager	: ✓
Metallic Plate (for fixing optical network unit)	: ✓
Fan Tray	: NA
Wheel	: NA
Total Weight	: 15.15kg

RWC12U300



Dimensions	Thickness
600(H) x 600(W) x 300(D)	1.1mm
Accessories	
Power Box PDU	: NA
Glass door with lock	: ✓
Vertical cable manager	: ✓
Metallic Plate (for fixing optical network unit)	: ✓
Fan Tray	: NA
Wheel	: NA
Total Weight	: 18.57kg

RWC12U500



Dimensions	Thickness
600(H) x 600(W) x 500(D)	1.1mm
Accessories	
Power Box PDU	: NA
Glass door with lock	: ✓
Vertical cable manager	: ✓
Metallic Plate (for fixing optical network unit)	: ✓
Fan Tray	: NA
Wheel	: NA
Total Weight	: 20.55kg

WALL CABINETS

12U CABINETS

Technical specifications

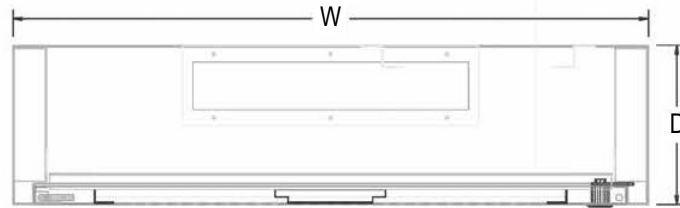

TOP VIEW

SIDE VIEW

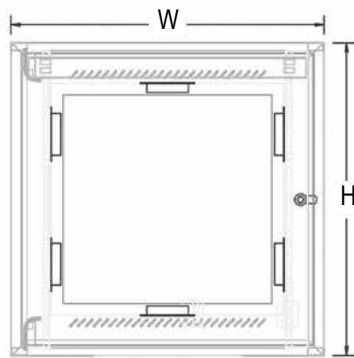
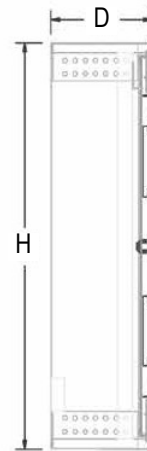

FRONT VIEW



ISOMETRIC VIEW

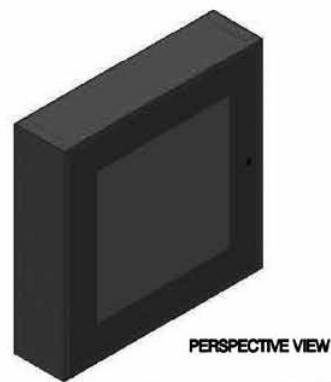

PERSPECTIVE VIEW

WALL CABINETS

RECESSED REMOVABLE DOOR & FRAME TYPE CABINETS



Features

- Easily removable door and frame. This enable to fix door & frame after all construction works which will improve durability and finish.
- Lockable, aesthetic glass door with quick release hinges.
- Easy knockouts on both top and bottom sides.
- Door can be hinged on left or right side.
- Adjustable powder coated rail mounting assembly.
- High quality powder coated CR steel body & frame.
- Various colour shades available as per customer requirements.

PART NO	DESCRIPTION
RWCRFR40/40/12	400X400X120 Wall Cabinet - Recessed
RWCRFR60/42/12	600X425X120 Wall Cabinet - Recessed
RWCRFR12U15	600X600X150 Wall Cabinet - Recessed
RWCRFR12U30	600X600X300 Wall Cabinet - Recessed
RWCRFR75/60/15	750X600X150 Wall Cabinet - Recessed
RWCRFR90/60/15	900X600X150 Wall Cabinet - Recessed

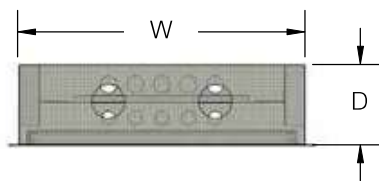

TOP VIEW

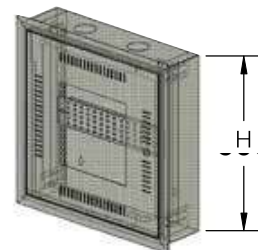

ISOMETRIC VIEW

WALL CABINETS

RECESSED WALL MOUNTED CABINETS



Features

- Recessed wall mounted.
- Lockable, aesthetic glass door with quick release hinges.
- Easy knockouts on both top and bottom sides.
- Door can be hinged on left or right side.
- Adjustable powder coated rail mounting assembly.
- High quality powder coated CR steel body & frame.
- Various colour shades available as per customer requirements.

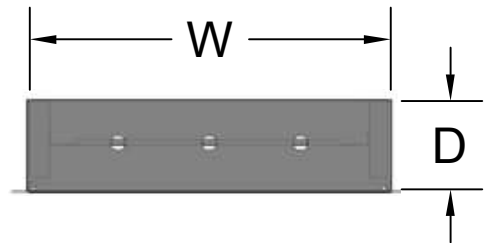

PART NO	DESCRIPTION
RWCRF40/40/12	400X400X120 Wall Cabinet - Recessed
RWCRF60/42/12	600X425X120 Wall Cabinet - Recessed
RWCRF12U15	600X600X150 Wall Cabinet - Recessed
RWCRF12U30	600X600X300 Wall Cabinet - Recessed
RWCRF75/60/15	750X600X150 Wall Cabinet - Recessed
RWCRF90/60/15	900X600X150 Wall Cabinet - Recessed

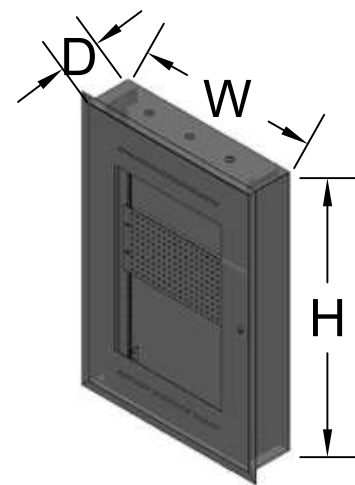

Floor Cabinets

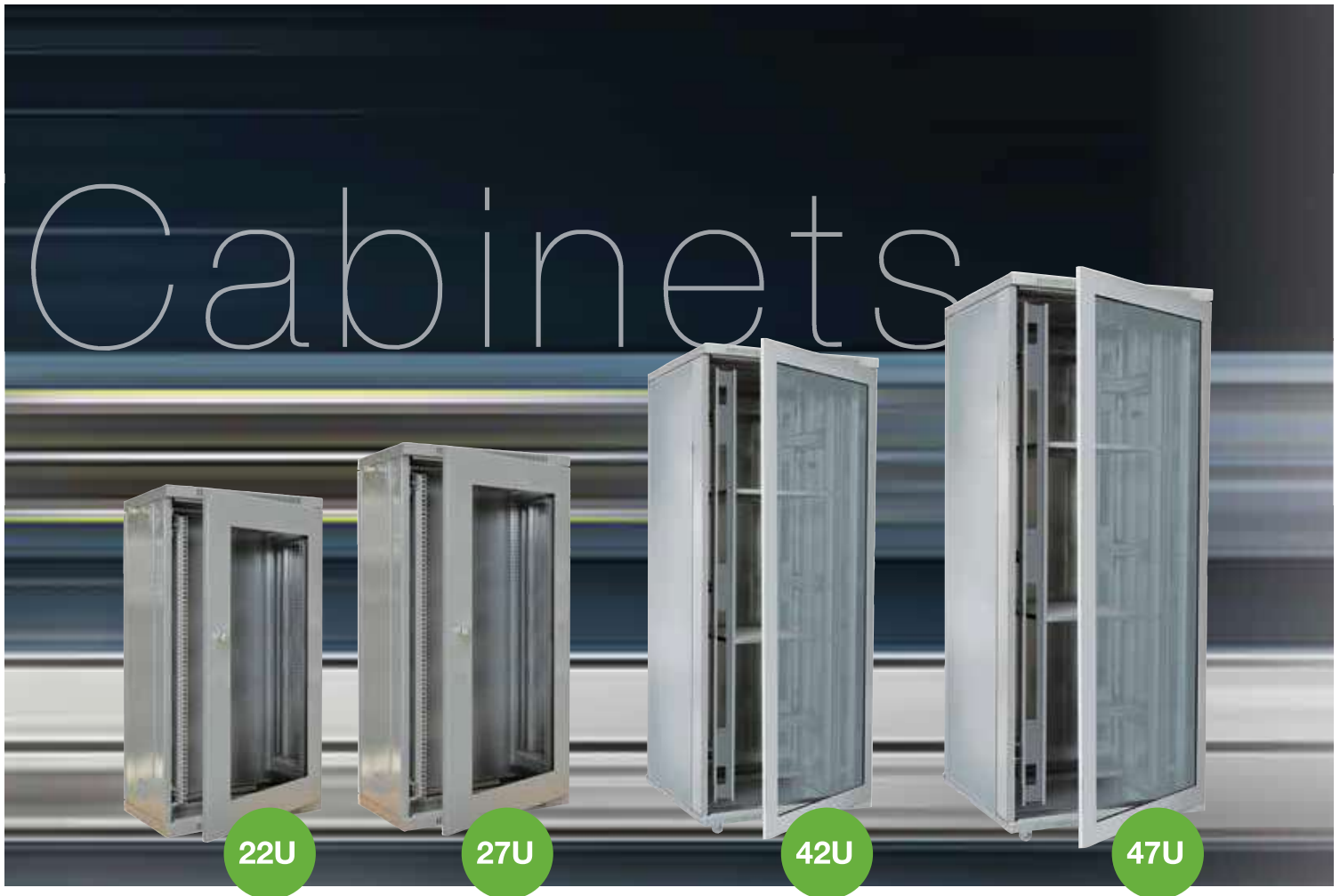

Features & Benefits

- Lockable lift-off side panels.
- Available either fully built or flat packed.
- Configurable top panels.
- Open base design with optional plinth.
- Plain steel, vented steel and glazed door options.
- 6 height variations- 750mm, 900mm, 1200mm, 1400mm, 2000mm & 2200mm.
- 2 width options, 600mm and 800mm.
- 2 depth available, 600mm and 800mm.
- Steel thickness: 1.5mm.
- Available in standard Light Grey.

Sizes & colors available as per requirement

FLOOR CABINETS

15U CABINETS

RFC15U450



Dimensions	Thickness
750(H) x 600(W) x 450(D)	1.5mm
Accessories	
Power Box PDU	: 6way PDU 13A or 15A 1No.
Glass door with lock	: ✓
Vertical cable manager	: ✓
Metallic Plate (for fixing optical network unit)	: NA
Fan Tray	: Two-way fan tray
Wheel	: NA
Total Weight	: 33.13kg

RFC15U550



Dimensions	Thickness
750(H) x 600(W) x 550(D)	1.5mm
Accessories	
Power Box PDU	: 6way PDU 13A or 15A 1No.
Glass door with lock	: ✓
Vertical cable manager	: ✓
Metallic Plate (for fixing optical network unit)	: NA
Fan Tray	: Two-way fan tray
Wheel	: NA
Total Weight	: 37.24kg

RFC15U600



Dimensions	Thickness
750(H) x 600(W) x 600(D)	1.5mm
Accessories	
Power Box PDU	: 6way PDU 13A or 15A 1No.
Glass door with lock	: ✓
Vertical cable manager	: ✓
Metallic Plate (for fixing optical network unit)	: NA
Fan Tray	: Two-way fan tray
Wheel	: NA
Total Weight	: 38.88kg

FLOOR CABINETS

15U CABINETS

Technical specifications

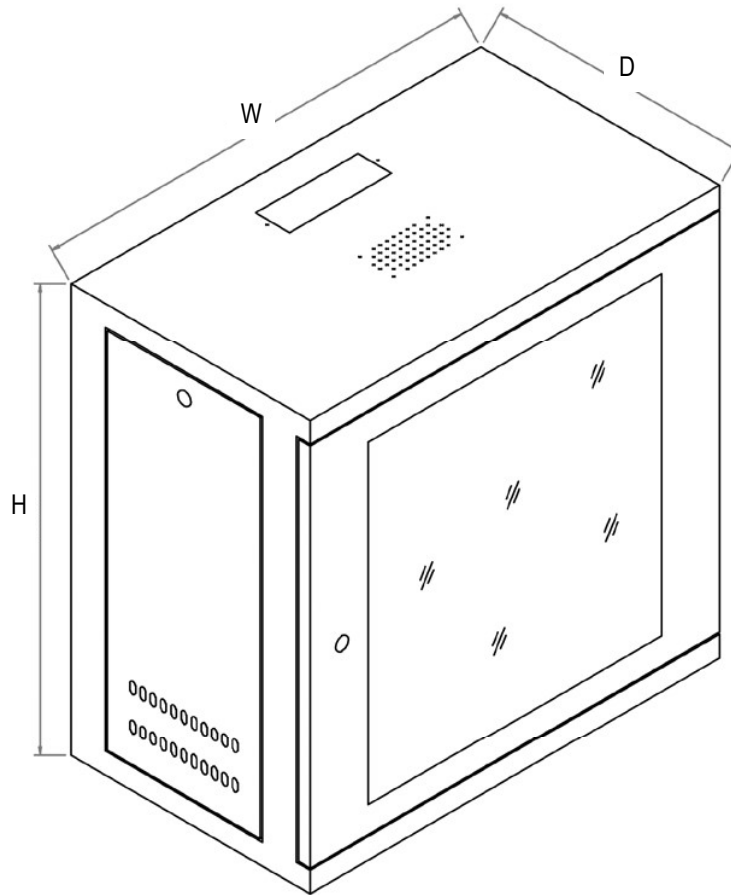

FLOOR CABINETS

18U CABINETS

RFC18U450



Dimensions	Thickness
900(H) x 600(W) x 450(D)	1.5mm
Accessories	
Power Box PDU	: 6way PDU 13A 1No.
Glass door with lock	: ✓
Vertical cable manager	: ✓
Metallic Plate (for fixing optical network unit)	: NA
Fan Tray	: Two-way fan tray
Wheel	: NA
Total Weight	: 43.39kg

RFC18U550



Dimensions	Thickness
900(H) x 600(W) x 550(D)	1.5mm
Accessories	
Power Box PDU	: 6way PDU 13A or 15A 1No.
Glass door with lock	: ✓
Vertical cable manager	: ✓
Metallic Plate (for fixing optical network unit)	: NA
Fan Tray	: Two-way fan tray
Wheel	: NA
Total Weight	: 47.37kg

RFC18U600



Dimensions	Thickness
900(H) x 600(W) x 600(D)	1.5mm
Accessories	
Power Box PDU	: 6way PDU 13A or 15A 1No.
Glass door with lock	: ✓
Vertical cable manager	: ✓
Metallic Plate (for fixing optical network unit)	: NA
Fan Tray	: Two-way fan tray
Wheel	: NA
Total Weight	: 53.13kg

FLOOR CABINETS

18U CABINETS

Technical specifications

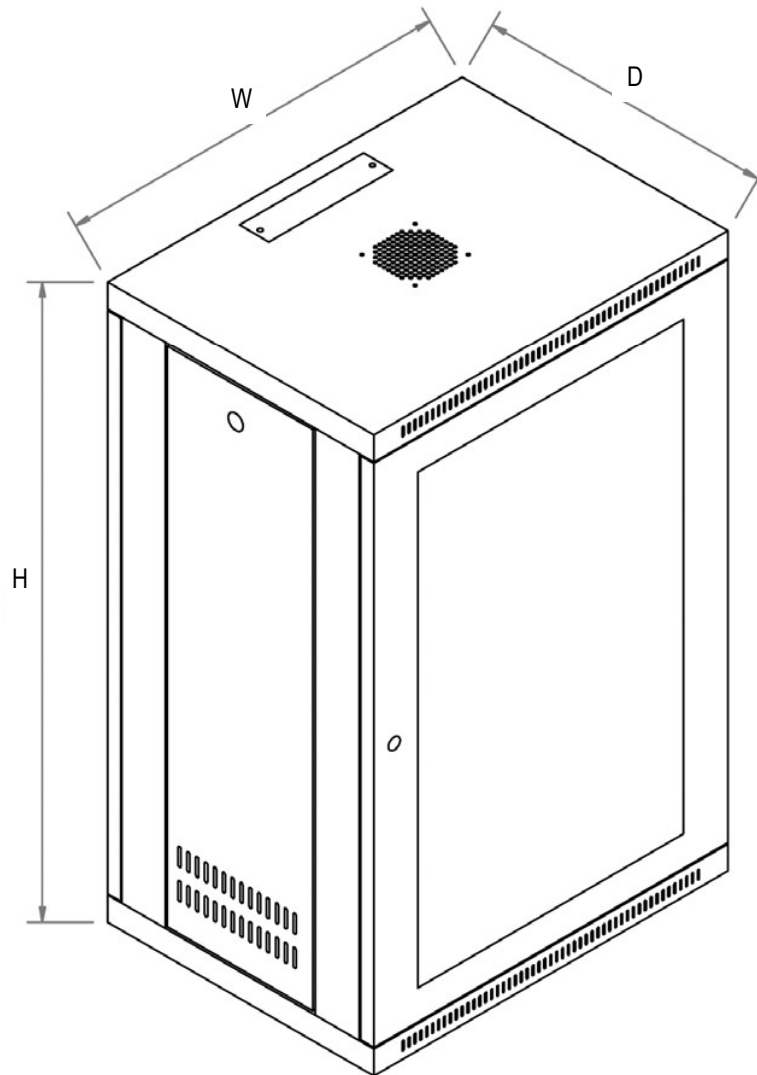

FLOOR CABINETS

22U CABINETS

RFC22U600



Dimensions	Thickness
1200(H) x 600(W) x 600(D)	1.5mm
Accessories	
Power Box PDU	: 6way PDU 13A or 15A 1No.
Glass door with lock	: ✓
Vertical cable manager	: ✓
Metallic Plate (for fixing optical network unit)	: Sliding shelf
Fan Tray	: Four-way fan tray
Wheel	: ✓
Total Weight	: 100.42kg

Technical specifications

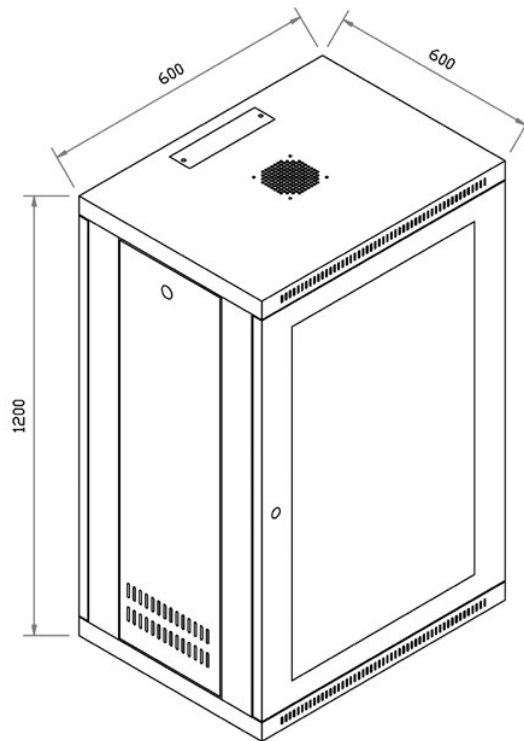

FLOOR CABINETS

27U CABINETS

RFC27U600



Dimensions	Thickness
1400(H) x 600(W) x 600(D)	1.5mm
Accessories	
Power Box PDU	: 6way PDU 13A or 15A 1No.
Glass door with lock	: ✓
Vertical cable manager	: ✓
Metallic Plate (for fixing optical network unit)	: Sliding shelf
Fan Tray	: Four-way fan tray
Wheel	: ✓
Total Weight	: 108.35kg

Technical specifications

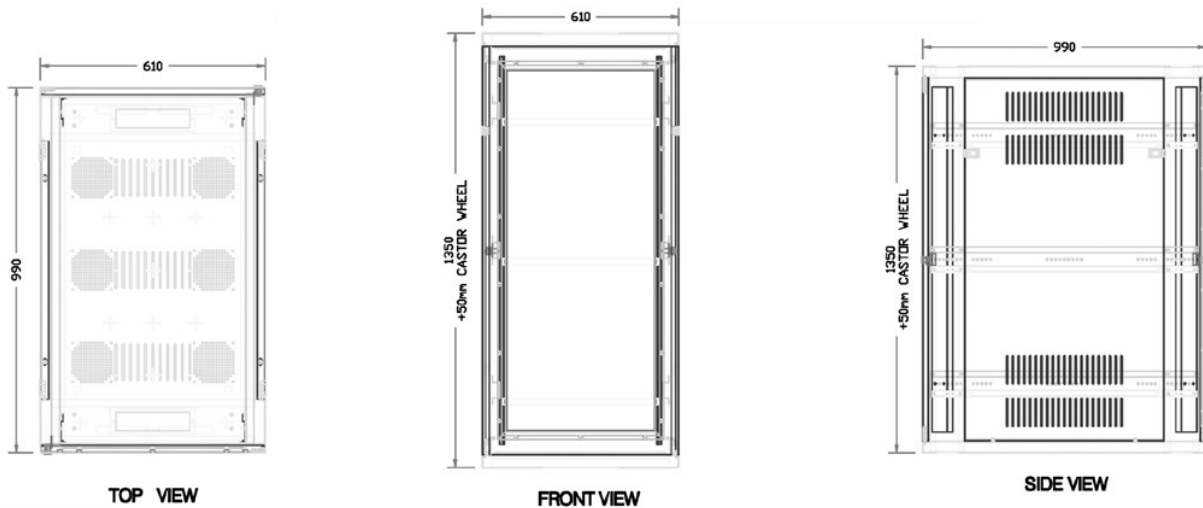

FLOOR CABINETS

42U CABINETS

RFC42U600



Dimensions	Thickness
2000(H) x 800(W) x 800(D)	1.5mm
Accessories	
Power Box PDU	: 6way PDU 13A or 15A 1No.
Glass door with lock	: ✓
Vertical cable manager	: ✓
Metallic Plate (for fixing optical network unit)	: Sliding shelf
Fan Tray	: Four-way fan tray
Wheel	: ✓
Total Weight	: 181.49kg

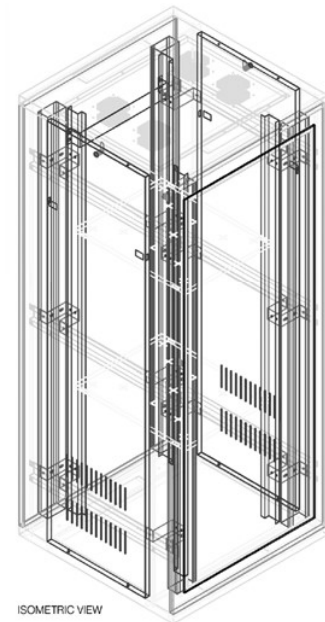
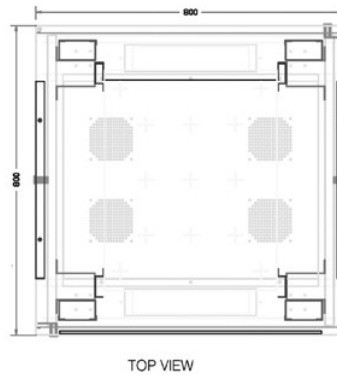
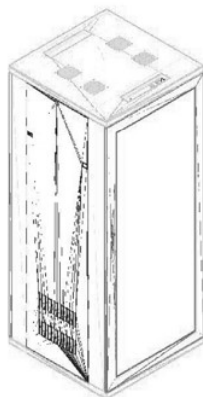
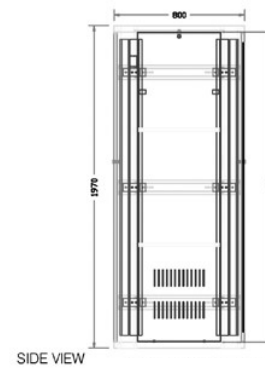
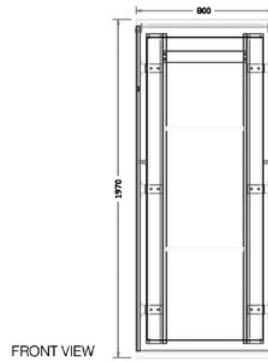

FLOOR CABINETS

47U CABINETS

RFC47U800



Dimensions	Thickness
2200(H) x 800(W) x 800(D)	1.5mm
Accessories	
Power Box PDU	: 6way PDU 13A or 15A 1No.
Glass door with lock	: ✓
Vertical cable manager	: ✓
Metallic Plate (for fixing optical network unit)	: Sliding shelf
Fan Tray	: Four-way fan tray
Wheel	: ✓
Total Weight	: 195.95kg

