

TYPE: 4W RAD

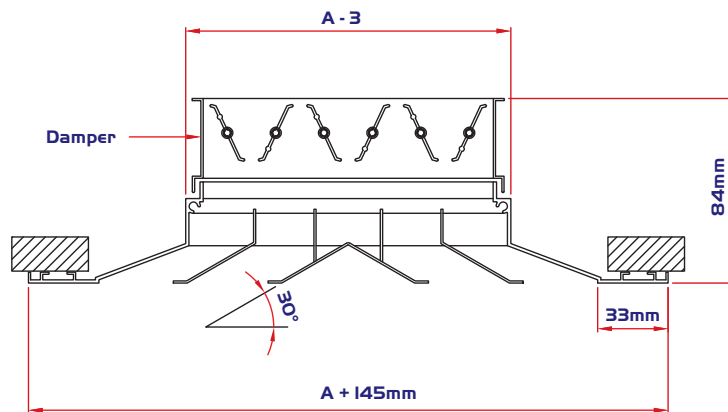

TYPE: 4W SAD

- >> Flush mounted with different pattern arrangements. Available in both square and rectangular shapes.
- >> Core is available in one way, two way, three way and four way discharge.
- >> Core is fixed to the frame by the action of spring loaded pins, It is easily removable to allow for maximum flexibility in installation, maintenance, damper adjustment and pattern exchange.





CEILING DIFFUSERS

- >> Stainless steel clips are fixed at the frame corners to assure maximum tightness and rigidity for the diffuser construction.
- >> Insulating gasket is fixed on request around the back of the frame to prevent infiltration between the frame and the ceiling.
- >> Available with easily removable opposed blade damper, attached to the frame by means of stainless steel (S) shape clips to ensure tight attachment with maximum flexibility.
- >> The ceiling diffuser may be used as a supply air diffuser or as a return air diffuser according to the application designed for both types can be supplied with a damper to control the static pressure loss and the air volume flow rate.

Finishing:

- Powder coated to RAL 9010/9016 (Standard) or other RAL codes.
- Natural anodized aluminium finish

SQUARE



RECTANGULAR



FIXING

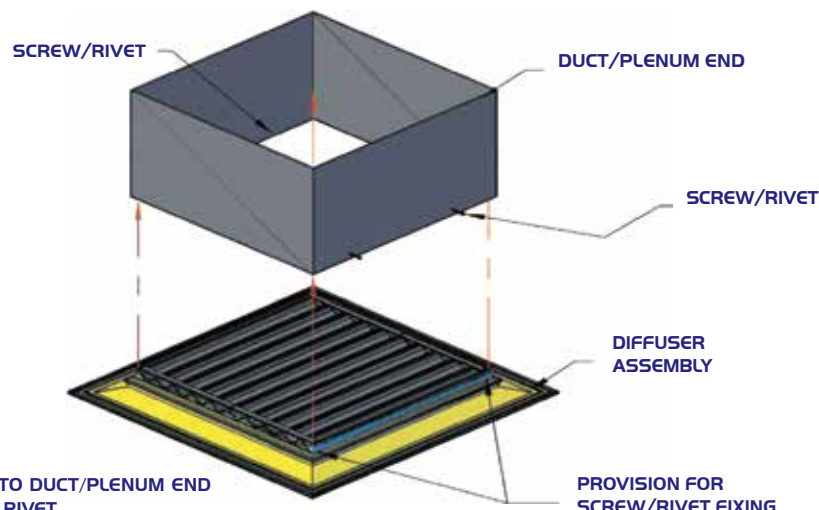

INSTALLATION:
STEP 1 - INSERT THE DIFFUSER INTO DUCT/PLENUM END
STEP 2 - TIGHTEN THE SCREW OR RIVET





OPTIONS

1 - EQUALIZING GRID (-EG) SAD - EG

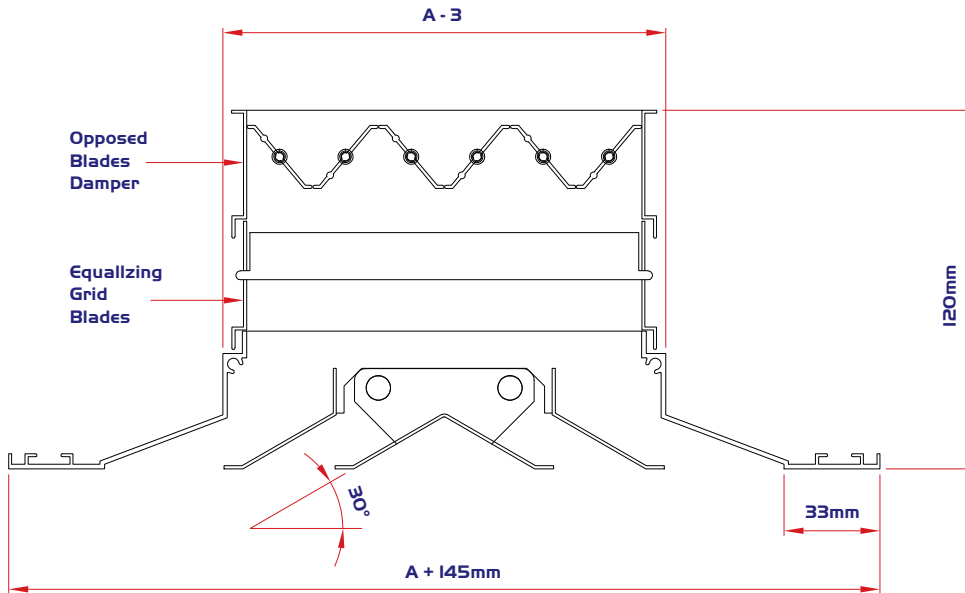

2 - G.I. NECK (-GN) RAD - GN

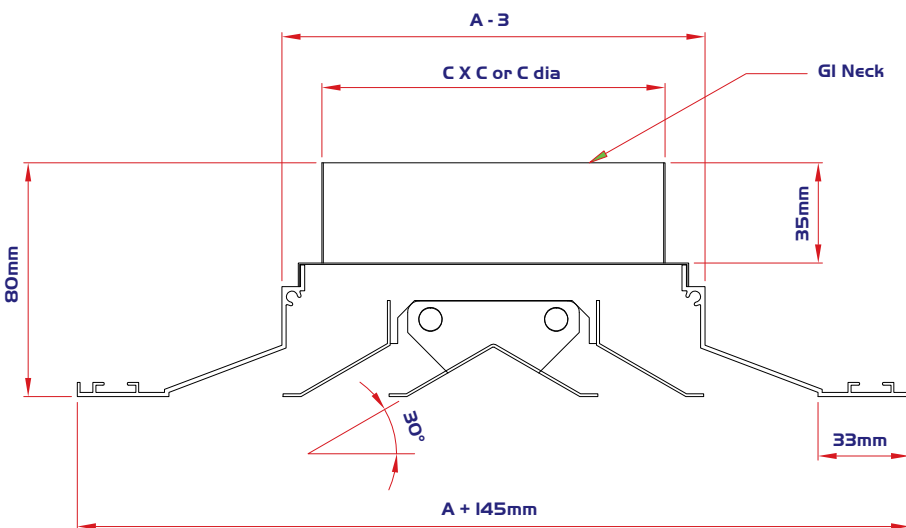



3 - 595 X 595 MM FACE PLATE FOR T-BAR CEILINGS (-TB) RAD - TB

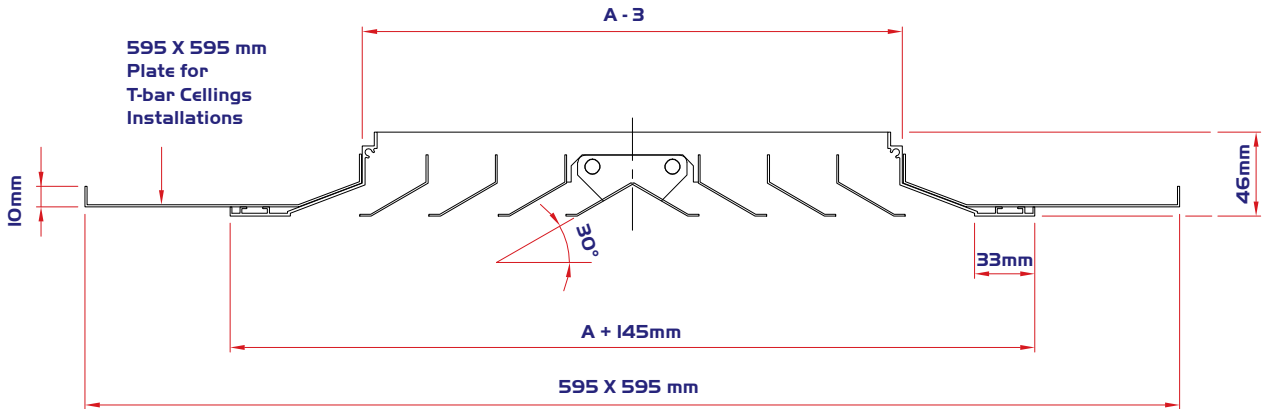

Ordering Key:

4	W	S	A	D	B	3	O	O	X	3	O	O	E	G	-
4W: 4 WAY (STANDARD) 3W: 3 WAY 2W: 2 WAY 1W: 1 WAY		SAD: WITH OPPOSED BLADES DAMPER (OBD) RAD: WITHOUT OPPOSED BLADES DAMPER (OBD)			M: MILL FINISH OBD (STANDARD) B: BLACK OBD		STANDARD SQUARE NECK SIZES: 150X150, 225X225, 300X300, 375X375, 450X450, 525X525 & 600X600MM STANDARD RECTANGULAR NECK SIZES: ANY COMBINATION OF 150, 225, 300, 375, 450, 525 & 600MM								
OPTIONAL ACCESSORIES: EG: EQUALIZING GRID GN: GI NECK TB: 595X595MM FACE FOR T-BAR INSTALLATIONS GI NECK SIZE (FOR ABOVE GN OPTION ONLY)															

