

TYPE: RLG

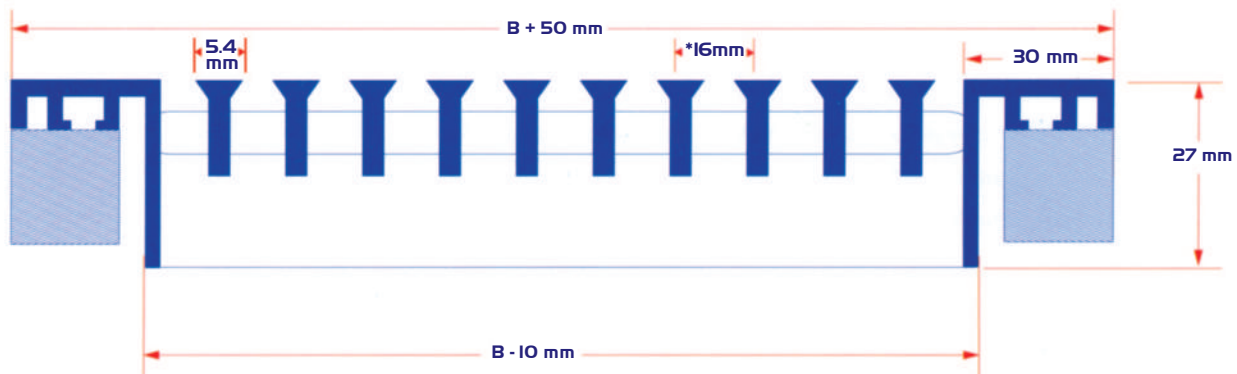

TYPE: RLR

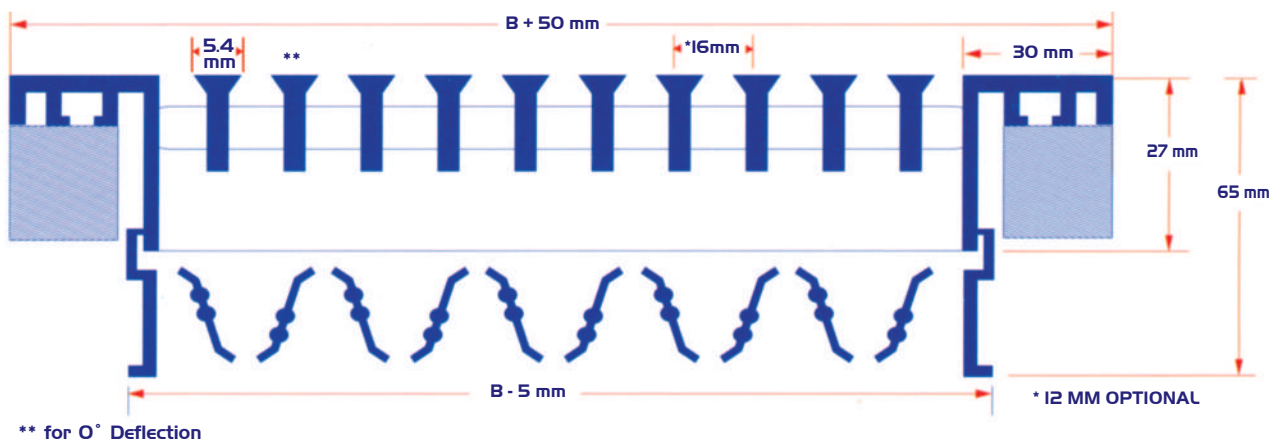

>> The single deflection linear grille is a wall mounted grille, used as an exhaust or return grille in cooling, heating or air ventilation applications.

>> The single deflection linear grille is composed of a set of fixed horizontal straight bars attached to a frame, both are manufactured from extruded aluminium sections.





LINEAR GRILLES & REGISTERS

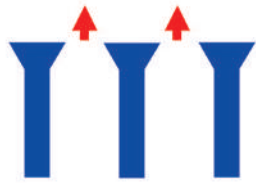

0° DEFLECTION (STANDARD)

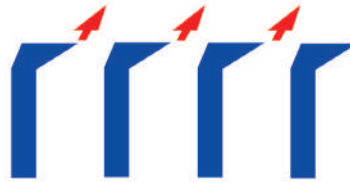

15° DEFLECTION, ONE WAY

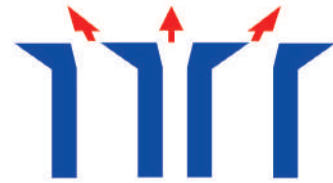

15° DEFLECTION, 2 WAY

>> Front bars have one of the following basic designs:

- 0° deflection bars (Standard)
- 15° deflection, one way
- 15° deflection, two way

>> Front bars are assembled in horizontal straight lines with a center to center spacing of 16 mm & 12 mm.

>> Available with easily removable opposed blades damper attached to the frame by means of (S) clips to ensure tight attachment and maximum flexibility. The damper is made of extruded aluminium bars and opening of the damper is easily adjusted by means of control lever that is driven by a screw driver from the front face of the register.

Available type of finishings :

- Natural anodized aluminium finish.
- Powder coated to RAL codes.

FIXING

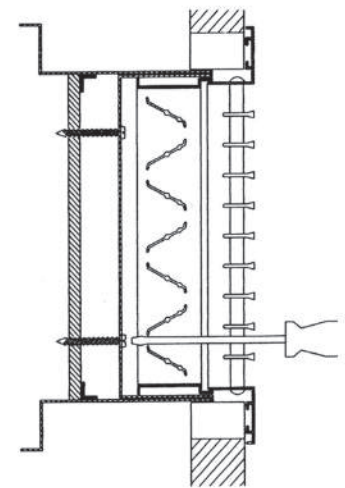
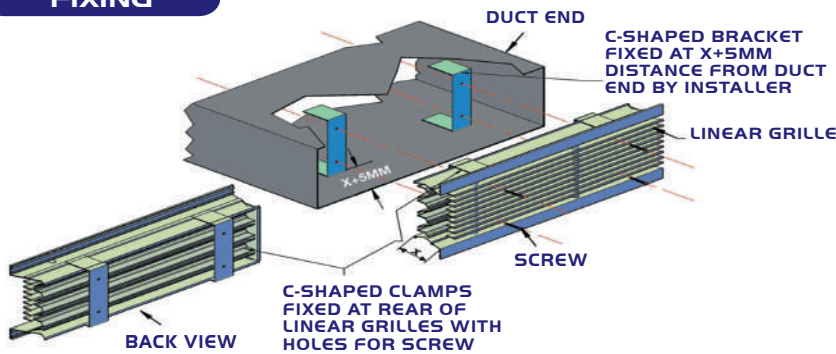

TYPES & MODELS

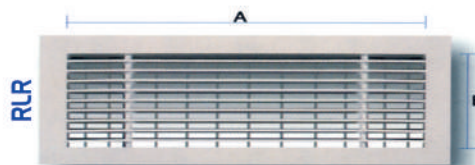
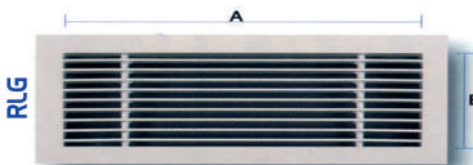

Ordering Key:

R	L	R	B	I6	C	R	V	SIZE
RLR: SINGLE DEFLECTION LINEAR REGISTER (WITH OBD) RLG: SINGLE DEFLECTION LINEAR GRILLE (WITHOUT OBD) RLR/RLG: COMBINED -: WITHOUT OBD B: WITH BLACK OBD M: WITH MILL FINISH OBD 16: 16MM CENTER-TO-CENTER SPACING 12: 12MM CENTER-TO-CENTER SPACING - - -: STRAIGHT LINEAR REGISTER/GRILLE CRV: CURVED LINEAR REGISTER/GRILLE COR: CORNER (STANDARD WITH 2 X 300MM SIDES & 90° ANGLE, OTHER SIDES & ANGLES CAN BE FABRICATED); EXAMPLE: RLG(16)/COR 300MM*300MM (90)*150MM SIZE: LENGTH X HEIGHT								

