



FIRE DAMPER FOR STATIC SYSTEMS - FDC/FDCA MODELS

SINGLE SECTION

FDC 100% FREE AREA



FDCA NOT 100% FREE AREA

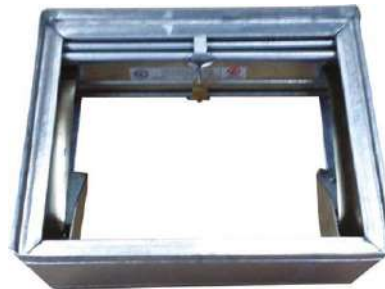

MULTIPLE SECTION

FDCA NOT 100% FREE AREA





FIRE DAMPER FOR STATIC SYSTEMS - FDC/FDCA MODELS

FEATURES:

- UL classified for static systems in accordance with UL 555 & NFPA 90A
- Civil Defence Approved
- Fusible link set at 165° F
- Fire rated for 1 1/2 hour
- Mounting type: vertical

MAXIMUM UL CLASSIFIED SIZES (OUT TO OUT)		
section	MAXIMUM WIDTH (")	MAXIMUM HEIGHT (")
SINGLE	36	36
MULTIPLE	72	72

CONSTRUCTION

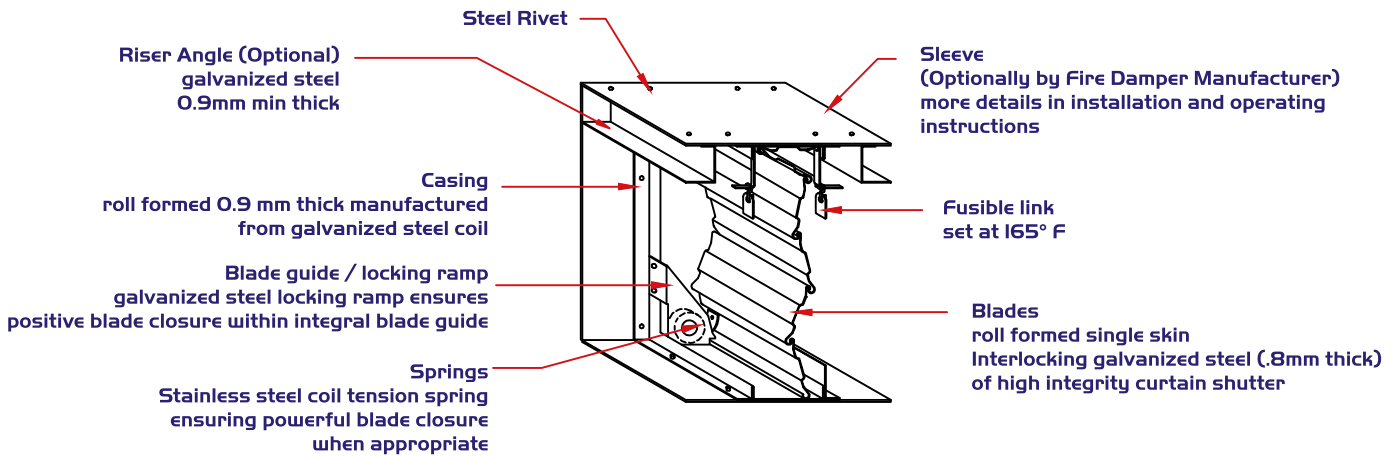

Figure - 1

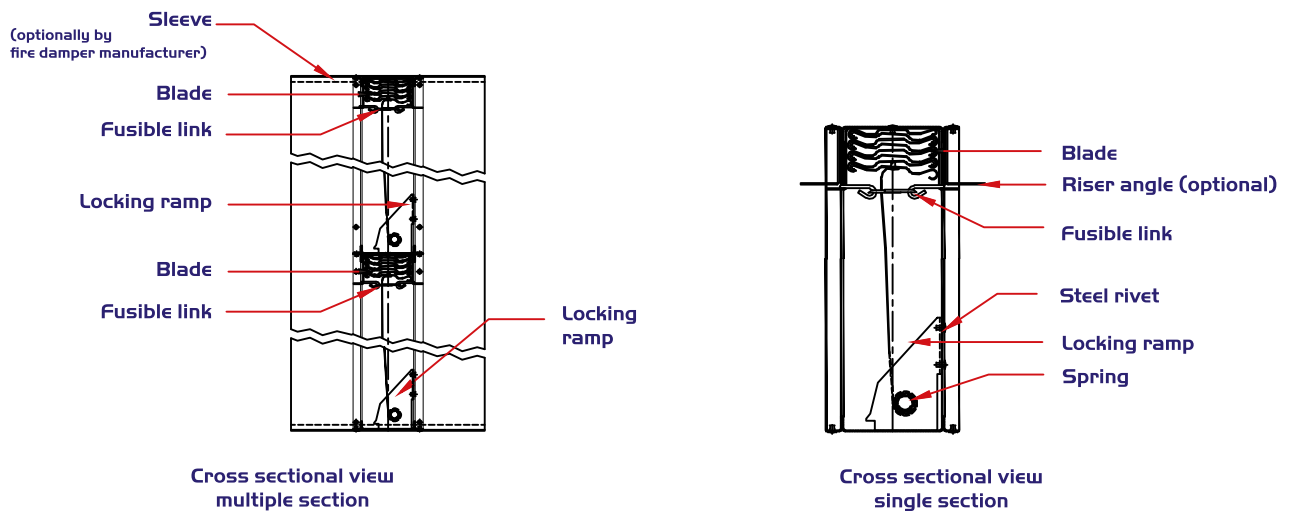

Figure - 2





**INSTALLATION AND OPERATING INSTRUCTIONS**

1. The damper (1) should be installed centrally within the surrounding masonry / gypsum floor or wall (7)
2. The damper (1) should be installed in a rectangular galvanized steel sleeve (2) (optionally by Fire Damper Manufacturer) with a minimum thickness of 0.9mm. This sleeve should be attached to the damper not to the builder's work using steel rivets (5) 4.8mm dia and spaced at not more than 225mm centers and 13 mm from corners (1/2")
3. The damper is suitable only for rectangular space and can not be use for annular space.
4. Allowance for expansion between sleeve and builder's work in both horizontal and vertical planes to be 3mm per 305 mm of length and width.
5. The sleeve (2) (optionally Fire Damper Manufacturer) should be of suitable length to extend through the wall to enable the fitting of the cover angles and ductwork.  
Minimum of 90 mm and maximum 152 mm beyond the floor or wall / include thicknesses of sleeve in table I.
6. The mounting angles (3) should be attached to the sleeve (optionally by Fire Damper Manufacturer) by 8mm dia (4) bolts at a maximum of 225 mm centers, and should form a complete frame around the sleeve and cover over the expansion gap (6) required between sleeve and wall / floor opening. The four corner of the mounting angles are not to be welded. The bolts connecting the mounting angles to the sleeve to be 102 mm maximum from the corners. Mounting angles will be send in loose parts.
7. The mounting angles (3) should be of such a size as always to form an overlap with the wall / floor by 25 mm minimum and should be manufactured from a minimum size of 35 x 35 x 2.5mm GI angle.
8. A fusible link is UL tested, Elsie brand, set at 165° F
9. The duct - sleeve connection to be of as per what shown in (figure 5) page (8) connecting ducts shall not be continuous and shall terminate at the sleeve. Installation shall comply with NFPA 90A
10. All fixing of frames must be positioned clear of the damper blade path so as not to impede proper closure.

Sleeve Thickness (mm)
0.9
1.2
1.5
2

TABLE I

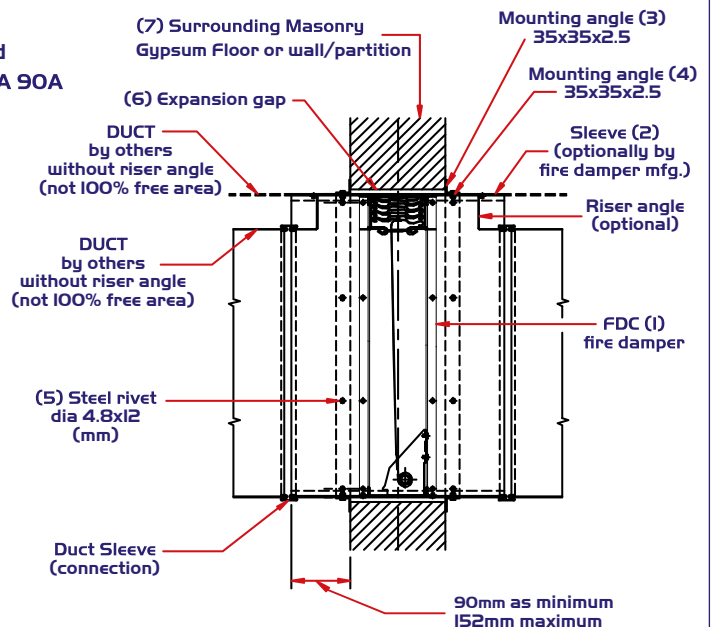

**Figure 3 (CROSS SECTION DETAILS)**  
SINGLE SECTION FDC FIX TO WALL

11. In Multiple Section FD center cross section point which obtain from attaching four individual section are welded from two sides.
12. In multiple section FD, Individual section FD attached with each other by steel rivet 4.8mm dia., space between rivet more than 225 mm centers, and (1/2") 13 mm from the corners.
13. Multiple section FD is enclosed with a single rectangular galvanized steel sleeve (optionally by Fire Damper Manufacturer).  
The fixing of the sleeve to the FD frame using steel rivet 4.8mm dia. Space not more than 225mm center to center and (1/2") 13 mm from corners. Sleeve (optionally by Fire Damper Manufacturer) thickness as per what mentioned on Table no. I
14. The maximum size of the multiple fire damper assembly that is assembled is 72" x 72".
15. In multiple section FD, The maximum size of the individual section that are attached together is 36" x 36".

**Figure 4 (FRONT VIEW)**  
MULTIPLE SECTION FDCA WITH SLEEVE

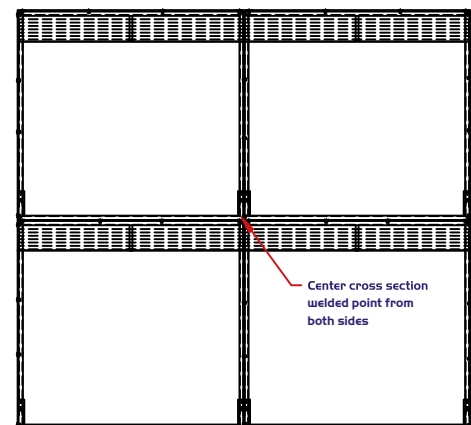



DUCT - SLEEVE CONNECTIONS

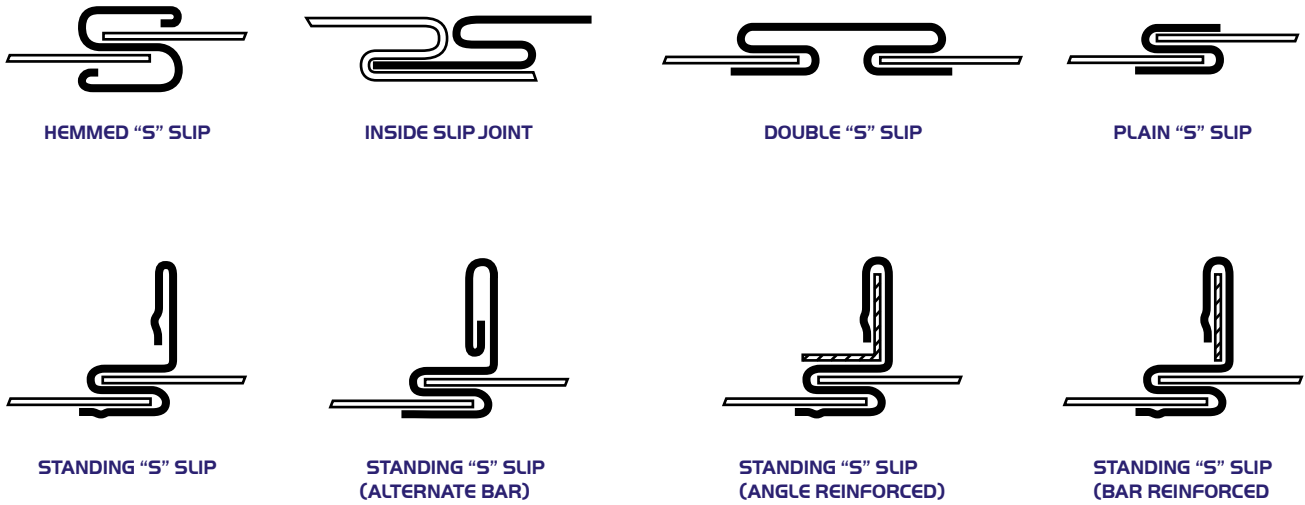

Figure - 5

EXPLODED ASSEMBLY FOR FDC TYPE WITH SLEEVE

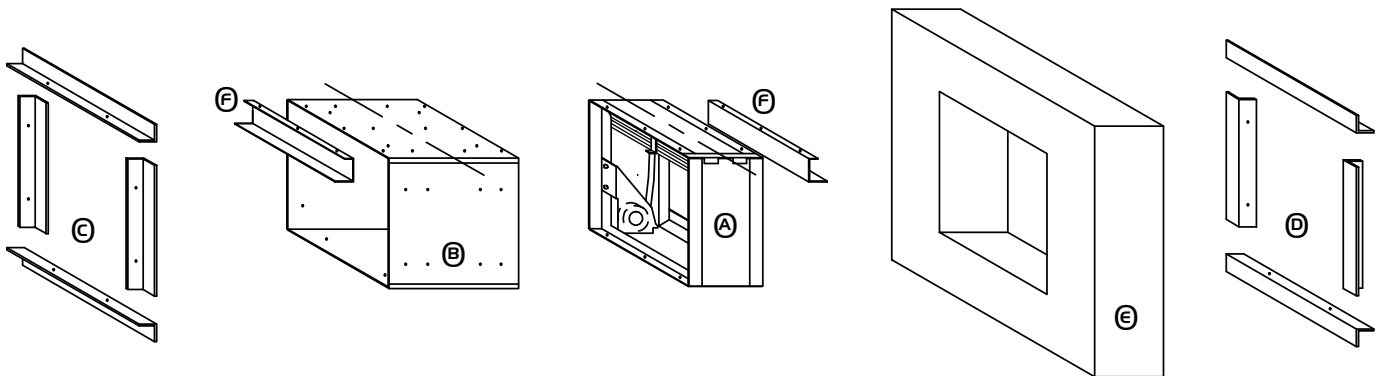

Figure - 6

ASSEMBLY PROCEDURES:

1. Fix the damper (A) into the sleeve (B) matching their center axis and hole provision using steel rivet.
2. If the riser angle (optional) is use then, fix the riser angle (C) (optional) into the fire damper sleeve matching their hole provision using steel rivet. If not go to step no.3.
3. Fix the fire damper with sleeve into the concrete / gypsum wall (E) opening by a front mounting angle (D) 35x35 matching their hole provision using M8 Hex bolt and nut. Opening size should have clearance of 3 mm per 305 mm of length and width.
4. Finally when the Fire Damper with sleeve is already fitted to the wall, fix the back mounting angle (D) 35 x 35 matching their hole provision using M8 Hex bolt and nut.





ORDERING SYSTEM

SINGLE SECTION

FDC 100% FREE AREA

SIZES RANGE

	( mm )	( inches )	X ( mm )	H ( mm )
H	80 - 825	3.2" - 32.5"	25	80 - 150
W	100 - 915	4" - 36"	50	151 - 450
			75	451 - 650
			90	651 - 825

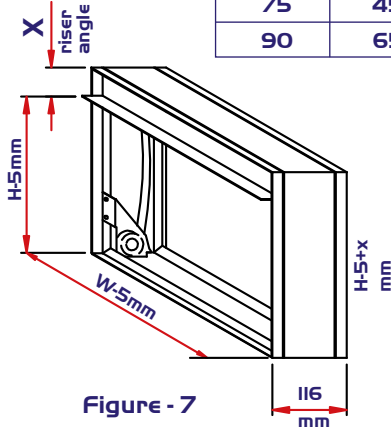

Figure - 7

FDCA NOT 100% FREE AREA

SIZES RANGE

	( mm )	( inches )
H	100 - 915	4" - 36"
W	100 - 915	4" - 36"

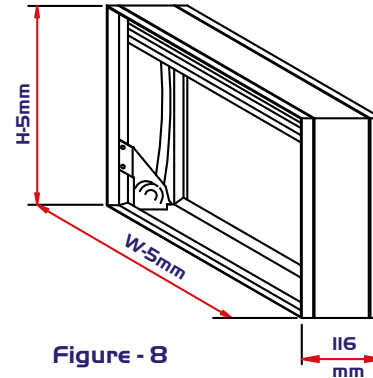

Figure - 8

MULTIPLE SECTION

FDCA NOT 100% FREE AREA

SIZES RANGE

Multiple Section

	( mm )	( inches )
H	above 915 - 1830	above 36" - 72"
W	above 915 - 1830	above 36" - 72"

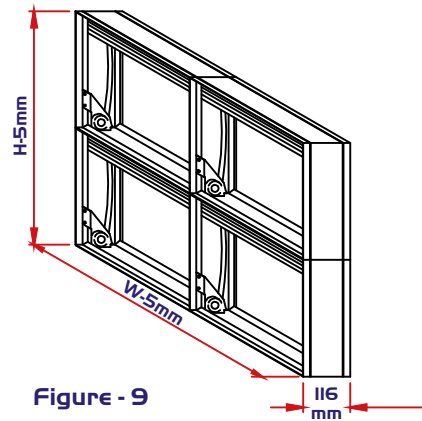

Figure - 9

Ordering Key:



STATIC	F	D	C	A	W	X	H	S	L	V	C	O	9
FIRE DAMPER FOR VERTICAL MOUNTING FOR STATIC APPLICATIONS													
- : 100% FREE AREA (STANDARD)													
A : NOT 100% FREE AREA													
SIZE: WIDTH X HEIGHT													
UP TO 36"X36" OUT-TO-OUT DIMENSIONS FOR SINGLE SECTION, AND 72"X72" OUT-TO-OUT DIMENSIONS FOR MULTIPLE SECTION.													
- : WITHOUT SLEEVE (STANDARD)													
SLVC09 : WITH 0.9 MM THICK G.I. SLEEVE													
SLVC12 : WITH 1.2MM THICK G.I. SLEEVE													
SLVC15 : WITH 1.5MM THICK G.I. SLEEVE													
SLVC20 : WITH 2.0MM THICK G.I. SLEEVE													

