



COMBINATION FIRE/SMOKE DAMPER

CLASS I - 350°F - CLASS I - 250°F - CLASS 2 - 250°F
 MODEL BMFSD (3 HR) / MODEL BEMFSD (1½ HR)

STANDARD CONSTRUCTION

Standards: Designed and tested in accordance with UL555 & UL555S. Meets NFPA 90A and SMACNA requirements for fire & smoke dampers.

Application: For fire & smoke barriers in dynamic fire & smoke management systems.

Frame: 133mm Roll formed hat-shaped made of 1.4mm thick galvanized steel with reinforced corners, having integral bracing and 90° perpendicular overlap at a corner.

Blades: Roll formed 3 V-shaped made of 1.4mm thick galvanized steel.

Bushes: Bronze bushes.

Axles: ¾" Square axles made of galvanized steel.

Linkage: Mechanical and concealed in frame.

Drive Mechanism: ½" Round Jack Shaft made of galvanized steel.

Jamb Seals: Stainless steel jamb seals.

Blades Seals: UL listed high-temperature (exceeding 450°F) Silicone blades edges seal/gasket manufactured in accordance with UL555S requirements.

Temperature Responsive Device: Resettable Thermoelectric set at 165° F.

Sleeve: Sleeve made of 400mm depth and 1.1mm thickness galvanized steel.

Mounting: Vertical mounting.

Fire Rating: 3 hr (Model BMFSD).

Air Flow Rating: 2000 FPM / 4 IWG.

Leakage: Available in Class I @ 350°F
 Class I @ 250°F
 Class 2 @ 250°F

Sizes: Single Section: Max. 36" X 36"
 Multiple Section: Max. 72" X 72"



Models BMFSD-T, BMFSDLT-T,
 BEMFSDLT-T & BEMFSD-T





COMBINATION FIRE/SMOKE DAMPER

CLASS I - 350°F - CLASS I - 250°F - CLASS 2 - 250°F
 MODEL BMFSD (3 HR) / MODEL BEMFSD (1½ HR)

OPTIONS

- Fire Rating: 1½ hr (Model BEMFSD & BEMFSDLT).
- Without Sleeve. With one side plate only (Models BMFSD-XS, BEMFSD-XS, BMFSDLT-XS & BEMFSDLT-XS).
- Round spigots for models BMFSD/R, BEMFSD/R, BMFSDLT/R & BEMFSDLT/R.

FEATURE	MODEL	BMFSD-T	BMFSD/R-T	BEMFSD-T	BEMFSD/R-T	BMFSDLT-T	BMFSDLT/R-T	BEMFSDLT-T	BEMFSDLT/R-T
		USE	FIRE BARRIER	✓	✓	✓	✓	✓	✓
	SMOKE BARRIER	✓	✓	✓	✓	✓	✓	✓	✓
SYSTEM	STATIC								
	DYNAMIC	✓	✓	✓	✓	✓	✓	✓	✓
AIR FLOW RATING	2000 FPM	✓	✓	✓	✓	✓	✓	✓	✓
PRESSURE RATING	4 IWG	✓	✓	✓	✓	✓	✓	✓	✓
LEAKAGE CLASS	CLASS 1 - 350	✓	✓	✓	✓				
	CLASS 1 - 250	✓	✓	✓	✓	✓	✓	✓	✓
	CLASS 2 - 250	✓	✓	✓	✓				
FIRE RATING	3 HR	✓	✓			✓	✓		
	1½ HR			✓	✓			✓	✓
MOTORIZED	NO								
	YES	✓	✓	✓	✓	✓	✓	✓	✓
ROUND SPIGOTS	WITH		✓		✓		✓		✓
	WITHOUT	✓		✓		✓		✓	
TEMPERATURE RESPONSIVE DEVICE	"165°F RESETTABLE THERMOELECTRIC TRD"	✓	✓	✓	✓	✓	✓	✓	✓
ACTUATOR	HONEYWELL 3.4Nm					✓	✓	✓	✓
	HONEYWELL 9Nm	✓	✓	✓	✓				
	BELIMO 20Nm	✓	✓	✓	✓				
SLEEVE	WITH	✓	✓	✓	✓	✓	✓	✓	✓
	WITHOUT	ABOVE MODELS WITHOUT ROUND SPIGOT CAN BE WITHOUT SLEEVE & WITH ONE SIDE PLATE WHEN THE MODEL ENDS BY "-XS"							



Models BMFSD/R, BEMFSD/R, BMFSDLT/R & BEMFSDLT/R

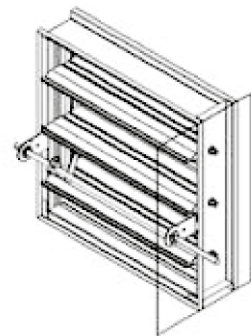

Models BMFSD-XS, BEMFSD-XS, BMFSDLT-XS & BEMFSDLT-XS





COMBINATION FIRE/SMOKE DAMPER

CLASS I - 350°F - CLASS I - 250°F - CLASS 2 - 250°F

MODEL BMFSD (3 HR) / MODEL BEMFSD (1½ HR)

ASSEMBLY

Single section assembly
up to 36"X36" (915X915mm)

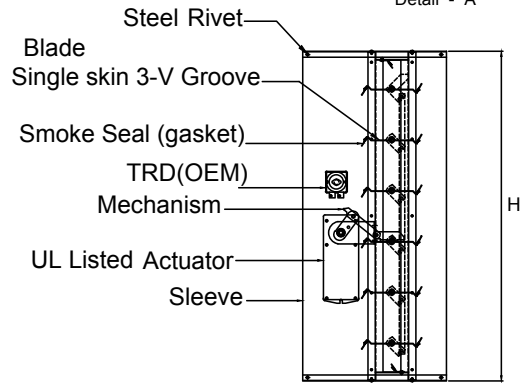
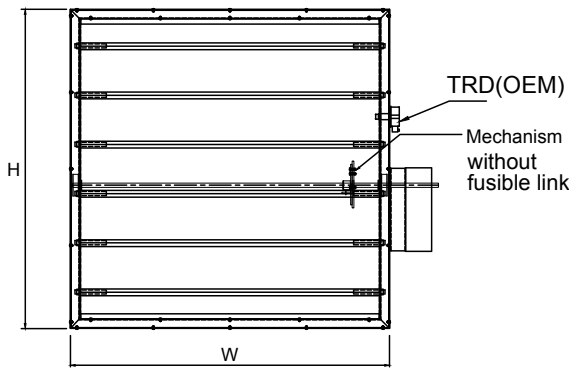
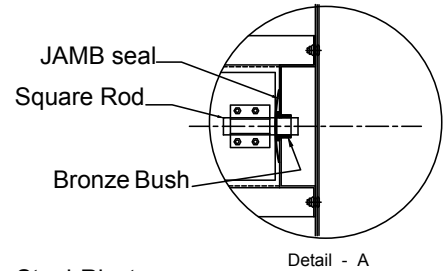
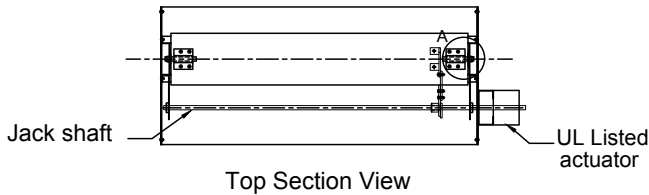

Multiple section assembly
up to 72"X72" (1830X1830mm)

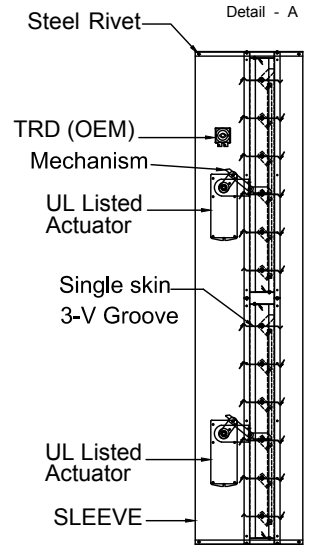
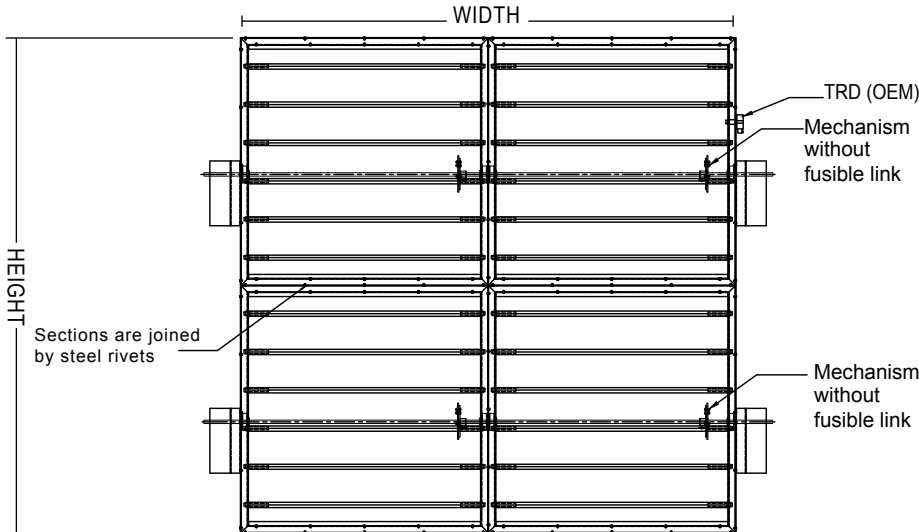
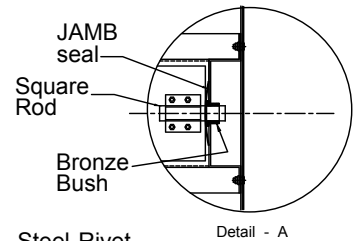
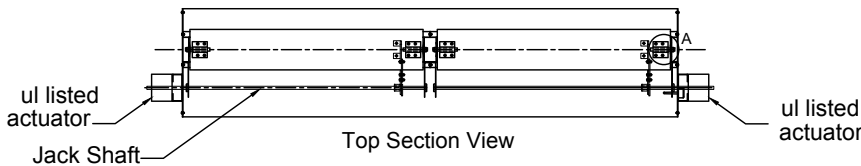



COMBINATION FIRE/SMOKE DAMPER

CLASS I - 350°F - CLASS I - 250°F - CLASS 2 - 250°F

MODEL BMFSD (3 HR) / MODEL BEMFSD (1½ HR)

PERFORMANCE DATA

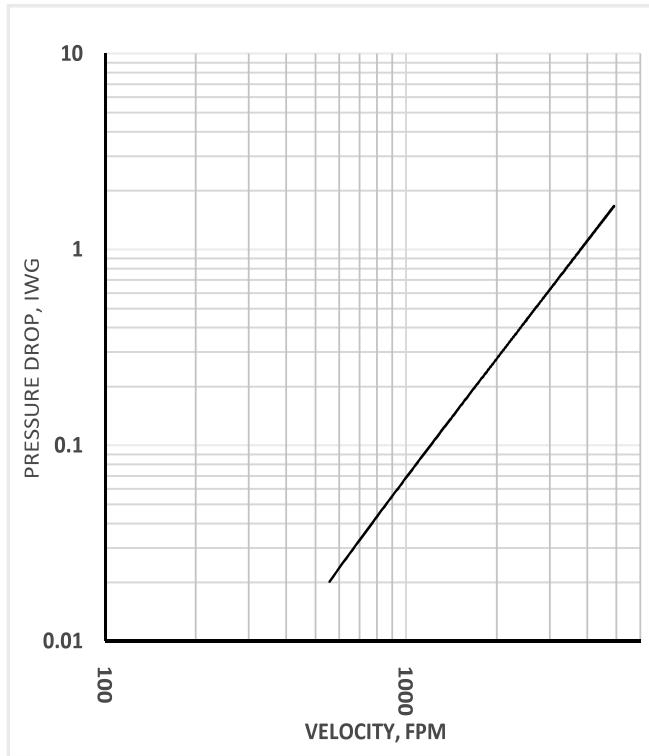

Note:
Pressure drop test was done at an independent laboratory in accordance with the AMCA 500-D standard on 36"X36" sample.

ORDERING KEY



B	MFSD	/Rd	-T	SIZE	XS
B: 3 HRS RATED BE: 1½ HRS RATED					
-- MFSD - MOTORIZED COMBINED FIRE & SMOKE DAMPER WITH 9Nm ACTUATOR -- MFSDLT - MOTORIZED COMBINED FIRE & SMOKE DAMPER WITH 3.4Nm ACTUATOR --: WITHOUT ROUND SPIGOT /Rd: WITH ROUND SPIGOTS OF "d" DIA. ("d" IS DIAMETER IN INCH UP TO 32")					
-T: WITH RESETTABLE THERMOELECTRIC 165°F TEMPERATURE RESPONSIVE DEVICE (TRD)					
SIZE: WIDTH X HEIGHT --MFSD - SINGLE SECTION: MAX. 36" X 36" MULTIPLE SECTION: MAX. 72" X 72" --MFSDLT - SINGLE SECTION: MAX. 20" X 20"					
--: WITH SLEEVE (STANDARD) XS: WITHOUT SLEEVE					





COMBINATION FIRE/SMOKE DAMPER

CLASS I - 350°F - CLASS I - 250°F - CLASS 2 - 250°F

MODEL BMFSD (3 HR) / MODEL BEMFSD (1½ HR)

INSTALLATION

(E)

INSTALLATION AND OPERATING INSTRUCTIONS FOR MODELS BMFSD-T, BMFSDLT-T, BEMFSD-T, BEMFSDLT-T, BMFSD/R-T, BMFSDLT/R-T, BEMFSD/R-T & BEMFSDLT/R-T

- 1) The damper (1) should be installed vertical, centrally and resting on the bottom opening within the surrounding masonry / gypsum wall (7). Actuator should be out of wall / gypsum partition as shown in (figure 1).
- 2) The damper (1) should be installed in a rectangular galvanized steel sleeve (2) with a minimum thickness of 1.1mm. This sleeve should be attached to the damper using M6 bolts (5) and spaced at not more than 110 mm centers and 30 mm from corners.
- 3) Clearance requirements for damper sleeves within a wall opening are based on 1/8 inch per foot (10mm per meter) of width or height unless otherwise stated in the listing of the assembly.
- 4) The sleeve (2) should be of suitable length to extend through the wall to enable the fitting of the cover angles and ductwork. Minimum of 90 mm from the wall and total depth of the sleeve should not exceed more than 510 mm.
- 5) The retaining angles (3) should be attached to the sleeve by 6 mm dia (4) bolts at a maximum of 110 mm centers, and should form a complete frame around the sleeve and cover over the expansion space (6) required between sleeve and wall opening. The four corner of the retaining angles are not to be welded. The bolts connecting the retaining angles to the sleeve to be 30mm maximum from the corners. Retaining angles will be send in loose parts.
Note: The retaining angles bolts should be out of the area of the damper frame.
- 6) The retaining angles (3) should be of such a size as always to form an overlap with the wall by 25mm minimum and should be manufactured from a minimum size of 35 x 35 x 1.5 mm GI.
- 7) Push the re-set button to reset the TRD 165°F.
- 8) The duct-sleeve connection to be of as per listed in UL 555s .
Connecting ducts shall not be continuous and shall terminate at the sleeve.
Installation shall comply with NFPA 90A.
- 9) All fixing of frames must be positioned clear of the damper blade path so as not to impede proper closure.

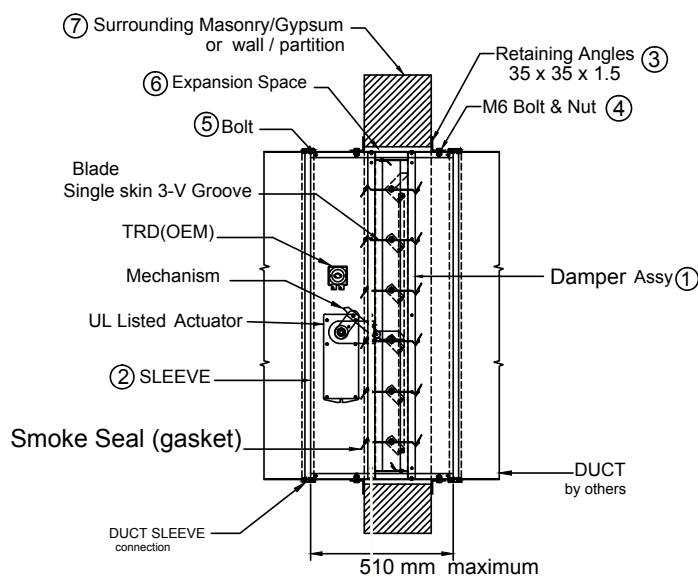

FIGURE 1





COMBINATION FIRE/SMOKE DAMPER

CLASS I - 350°F - CLASS I - 250°F - CLASS 2 - 250°F
 MODEL BMFSD (3 HR) / MODEL BEMFSD (1½ HR)

INSTALLATION

EXPLODED ASSEMBLY WITH SLEEVE:

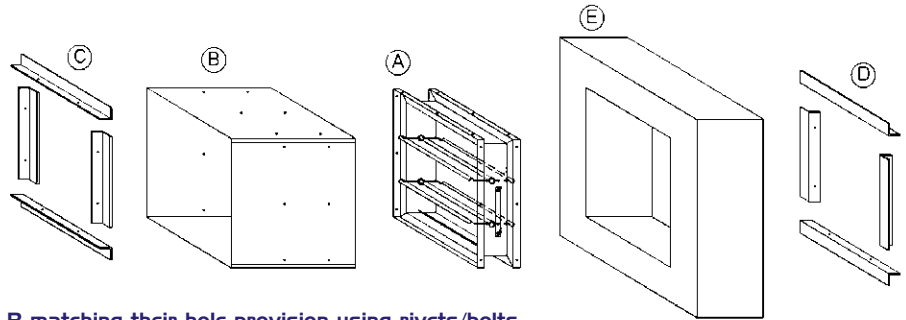

ASSEMBLY PROCEDURES:

- 1- Fix the damper A into the sleeve B matching their hole provision using rivets/bolts.
- 2- Fix the damper with sleeve into the concrete/gypsum wall opening E using the front retaining angle C 35X35 and matching their hole provision using M6 Hex bolt & nut. The sleeve B must overhang by a minimum of 90mm and maximum of 152mm. Opening size should have clearance of 3mm per 305mm of width and height.
- 3- Finally, when the subassembly is already fitted to the wall, fix the back retaining angle D 35X35 using M6 Hex bolt & nut.

DUCT-SLEEVE CONNECTIONS

FLANGED BREAKWAY CONNECTIONS:

TDC AND TDF ROLL-FORMED 4-BOLT FLANGED CONNECTIONS ASSEMBLED PER THE MANUFACTURER'S INSTRUCTIONS USING GASKETS, METAL CLEATS AND FOUR 9.5 mm METAL NUTS AND BOLTS.

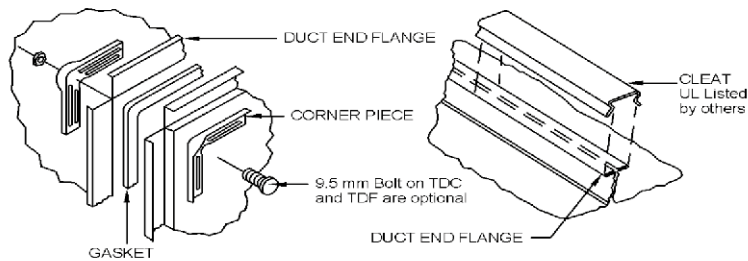

MANUFACTURED SLIP ON 4-BOLT FLANGED CONNECTIONS ASSEMBLED PER THE MANUFACTURER'S INSTRUCTIONS USING GASKETS AND PLASTIC CLEATS AS SHOWN BELOW.

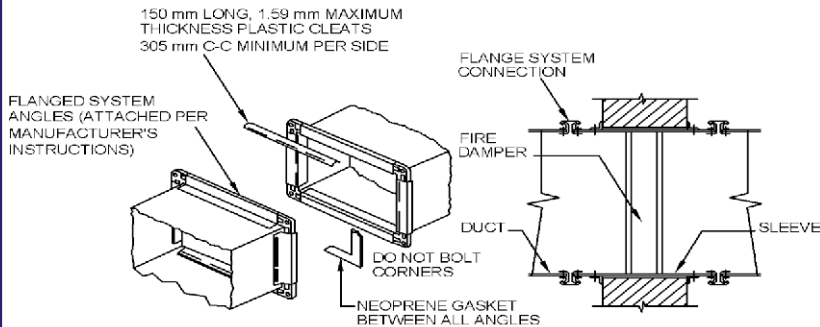

(UL TESTED CONNECTIONS BY OTHERS)

TRANSVERSE JOINTS BREAKWAY CONNECTIONS (WITHOUT FLANGES):

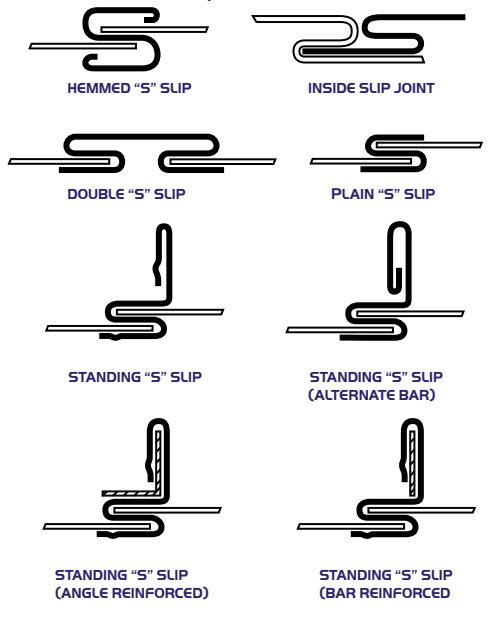

R21930

