

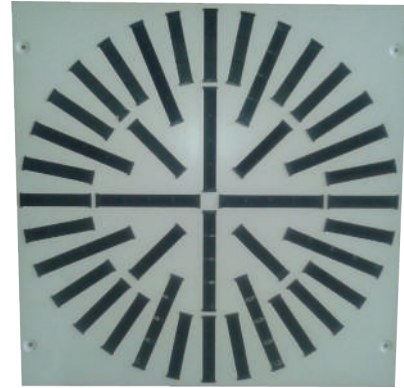

ADJUSTABLE RADIAL-STAR DEFLECTION TYPE - MODEL SW3

STANDARD CONSTRUCTION

- A radial-star array of adjustable black plastic cylindrical deflectors attached to slots into a square steel panel.
- With one counter sunk hole at the center for fixing.
- Powder coated to RAL 9010/9016.



Model SW3

APPLICATION

- For ceiling heights up to 4m.
- For high induction requirements (with VAV)
- For adjustable swirl air pattern.
- For Supply & Return air use.

DIMENSIONS

Size	mm				mm ²	
	□F	P	M	N	A _{ef} SS	A _{ef} SR
310	308	59	190	270	0.019	0.012
400	398	64	270	360	0.025	0.025
500	498	64	370	460	0.052	0.039
600	598	69	460	560	0.072	0.057
625	623	81.5	460	560	0.072	0.057
800	798	124	550	760	0.136	0.094

SW3-SR4

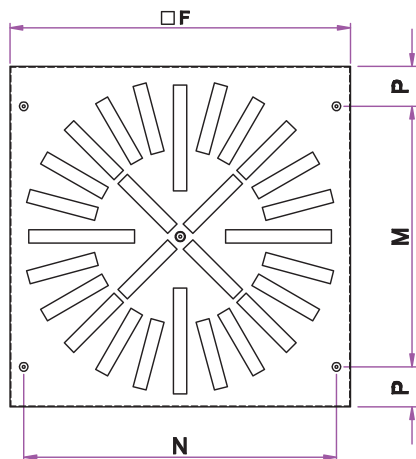

SW3-R

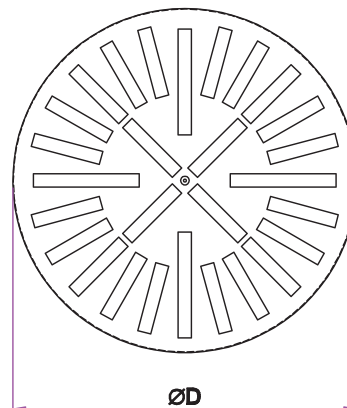



ADJUSTABLE RADIAL-STAR DEFLECTION TYPE - MODEL SW3

DIMENSIONS

SQUARE TYPE WITH PLENUM BOX & VCD AT SIDE SPIGOT: MODEL SW3SRIDPSV

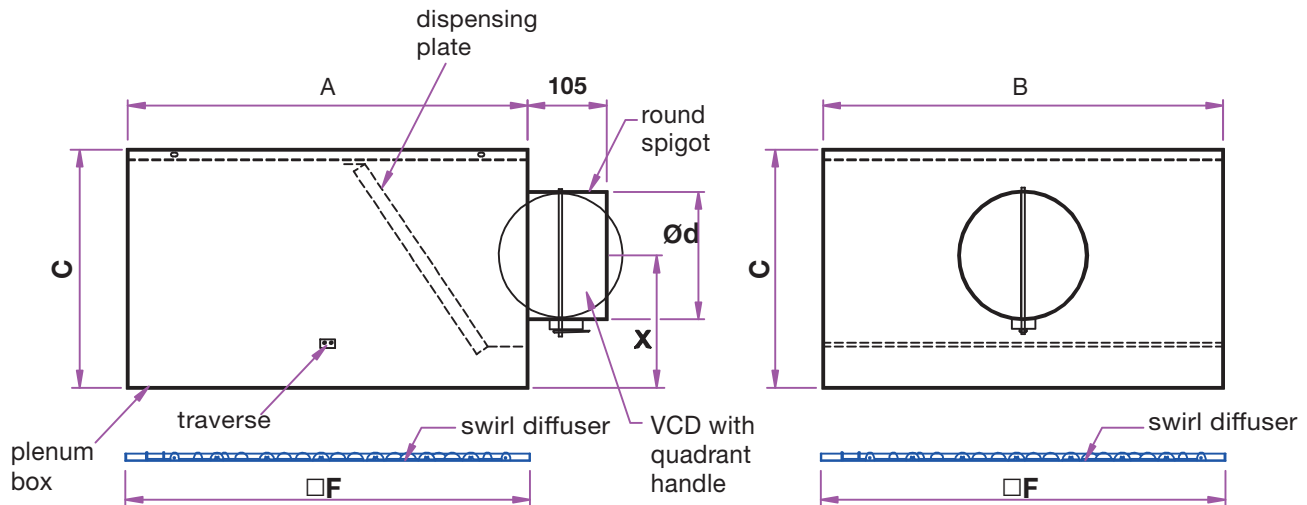

SQUARE TYPE WITH PLENUM BOX & VCD AT TOP SPIGOT: MODEL SW3SRIDPTV

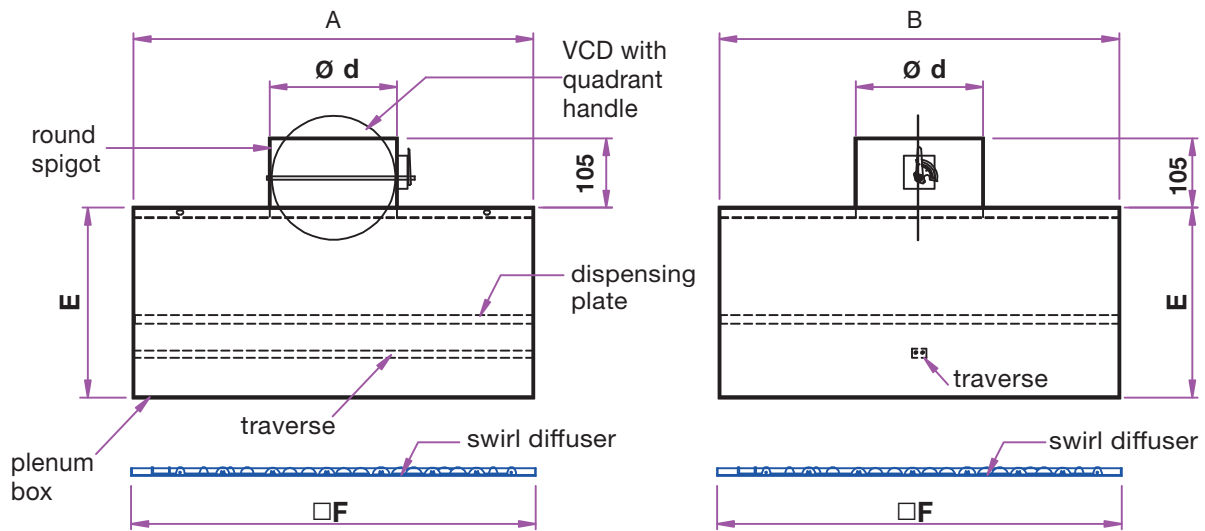

Size	mm						
	□F	A	B	C	X	E	Ød
310 SR, SS	308	325	325	240	137	200	158
400 SR, SS	398	390	390	290	167	240	198
500 SR, SS	498	590	590	325	177	240	248
600 SR, SS	598	590	590	325	177	240	248
625 SR, SS	623	590	590	325	177	240	248
800 SR, SS	798	790	790	450	250	300	313





ADJUSTABLE RADIAL-STAR DEFLECTION TYPE - MODEL SW3

DIMENSIONS

ROUND TYPE WITH PLENUM BOX & VCD AT SIDE SPIGOT: MODEL SW3RRDPSV

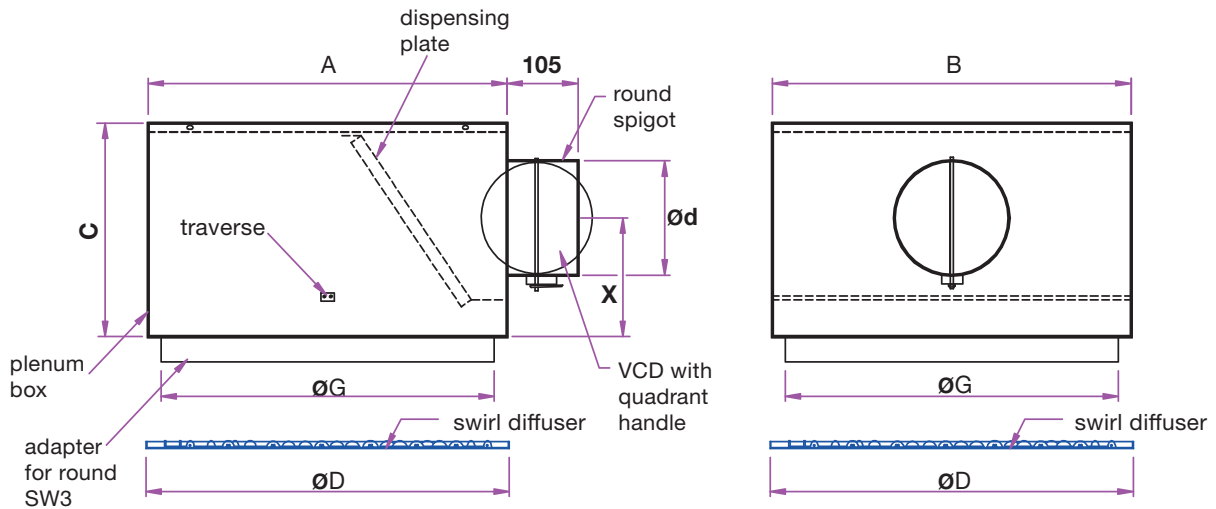

ROUND TYPE WITH PLENUM BOX & VCD AT TOP SPIGOT: MODEL SW3RRDPTV

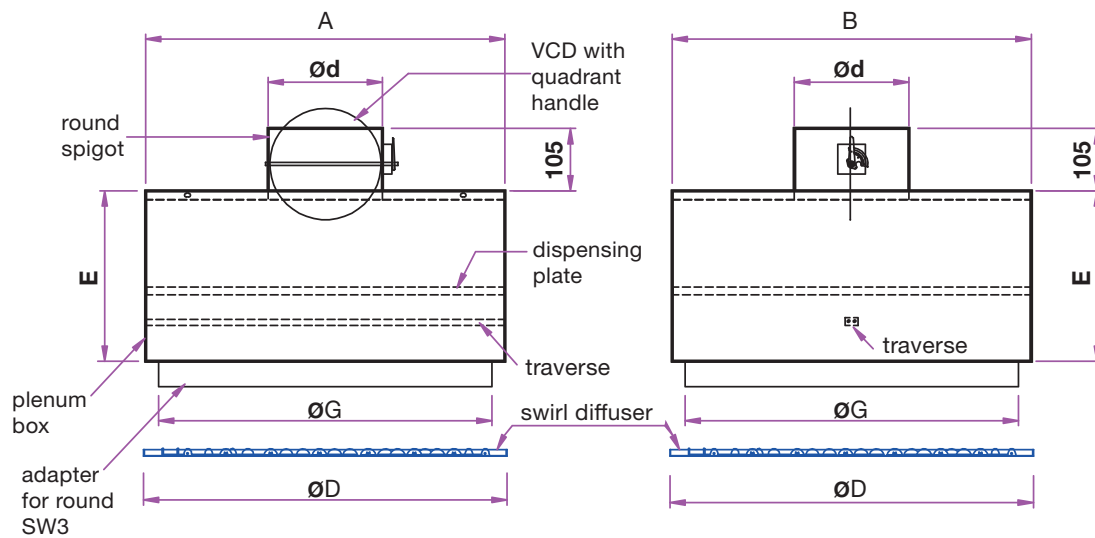

Size	mm							
	ØD	ØG	A	B	C	E	X	Ød
310	310	300	320	320	240	200	137	158
400	400	370	390	390	290	240	167	198
500	500	470	490	490	325	240	177	248
600	600	570	590	590	325	240	177	248
625	625	570	590	590	325	240	177	248
800	800	760	790	790	450	300	250	313





ADJUSTABLE RADIAL-STAR DEFLECTION TYPE - MODEL SW3

SIZES & DEFLECTORS ARRAY

SW3-SR SW3-R SW3-SS

SIZE 310

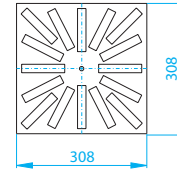
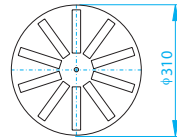
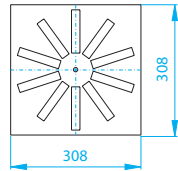

SIZE 400

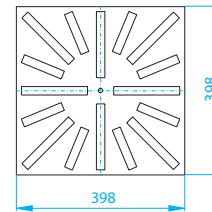
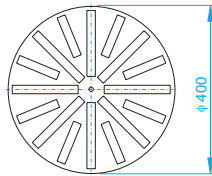
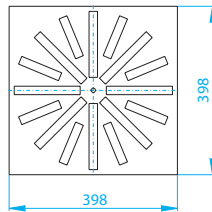

SIZE 500

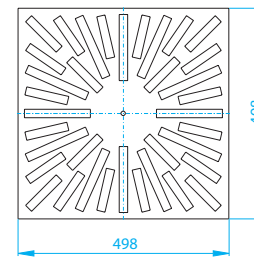
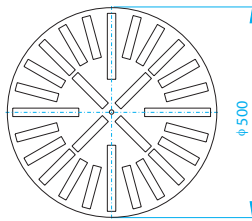
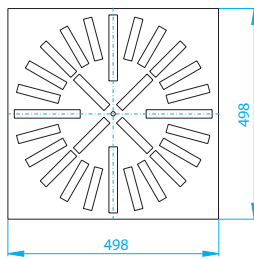

SIZES 600 & 625

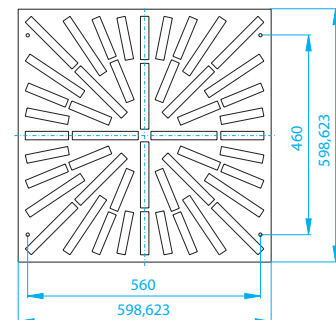
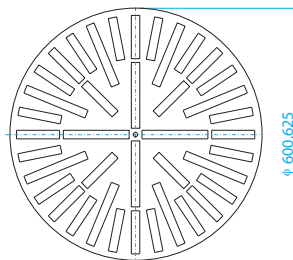
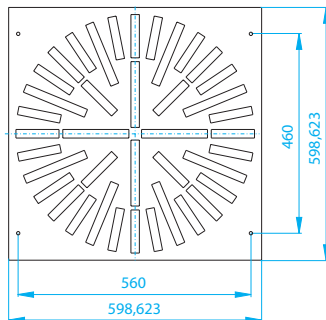

SIZE 800

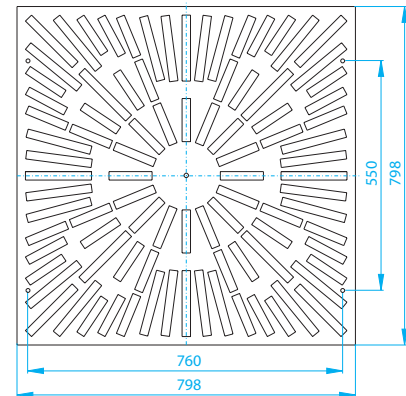
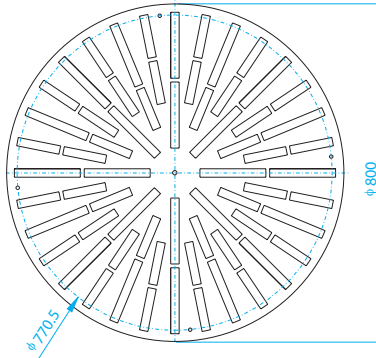
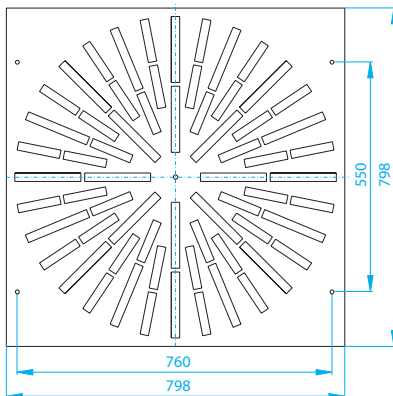



ADJUSTABLE RADIAL-STAR DEFLECTION TYPE - MODEL SW3

PERFORMANCE DATA

THROW:

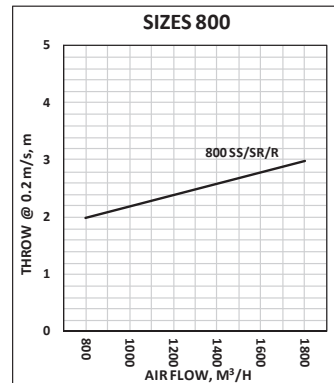
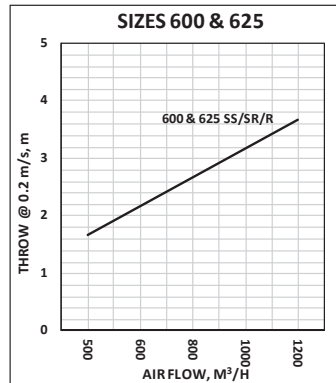
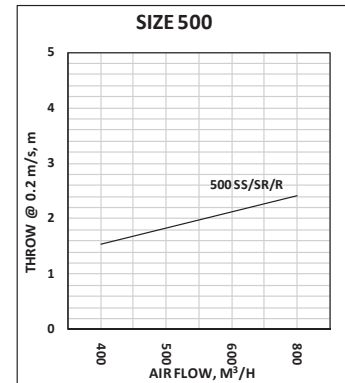
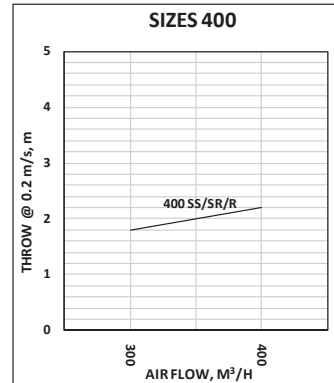
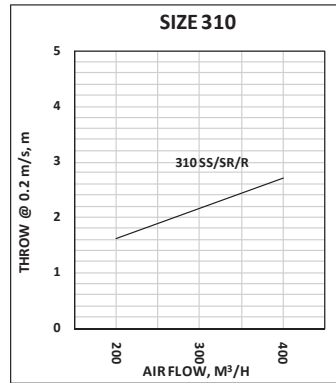

PRESSURE DROP:

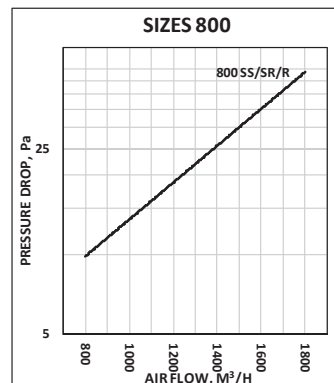
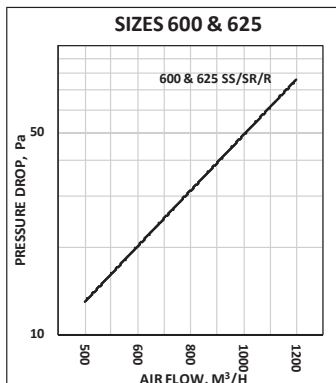
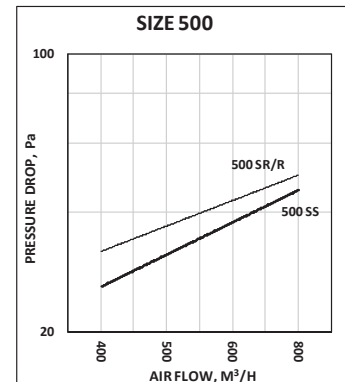
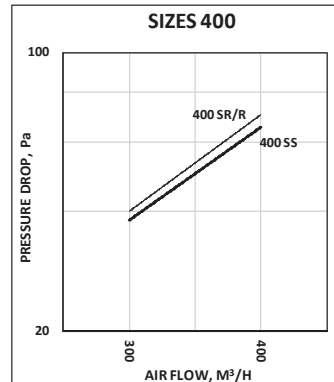
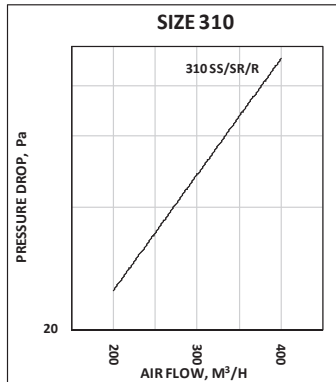



ADJUSTABLE RADIAL-STAR DEFLECTION TYPE - MODEL SW3

PERFORMANCE DATA

SOUND DATA:

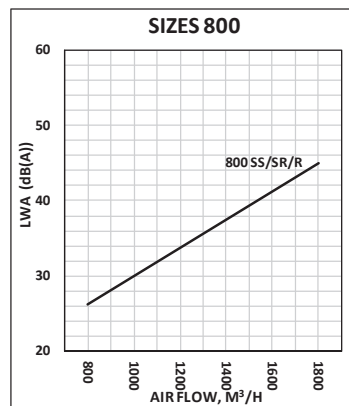
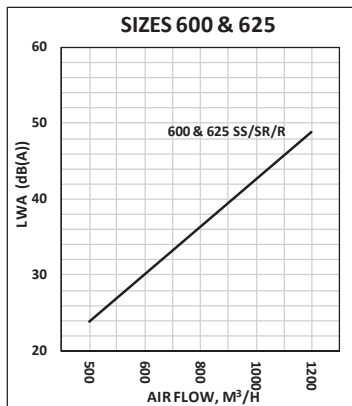
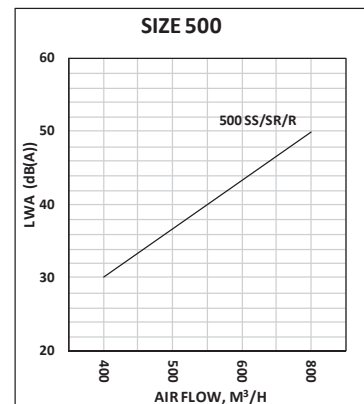
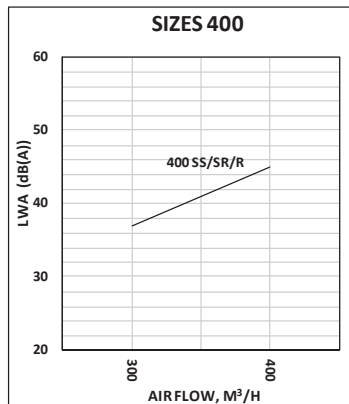
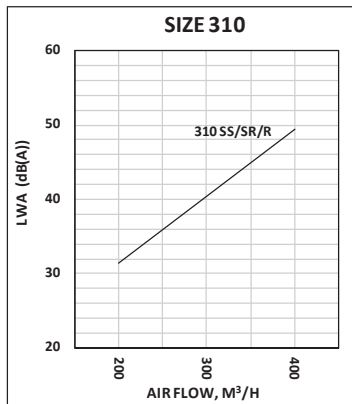

Ordering Key:

S	W	3	S	R	I	D	PT	V	600
SWIRL DIFFUSER TYPE 3 ADJUSTABLE RADIAL-STAR DEFLECTION									
S: SQUARE FACE R: ROUND FACE									
S: SQUARE ARRANGEMENT OF DEFLECTORS R: ROUND ARRANGEMENT OF DEFLECTORS									
I: FACE IS FIXED BY I SCREW AT CENTER 4: FACE IS FIXED BY 4 SCREWS AT CORNERS									
D: WITH AIR DEFLECTORS -: WITHOUT AIR DEFLECTORS									
PT: WITH PLENUM BOX & SPIGOT AT TOP PS: WITH PLENUM BOX & SPIGOT AT SIDE									
V: WITH VOLUME CONTROL DAMPER TO BE FIXED AT SPIGOT OF PLENUM BOX									
SIZE: FACE SIDE OR DIAMETER 310, 400, 500, 600, 625 OR 800									

