

WE GUIDE AIR



BETA
industrial
PRODUCTS CATALOGUE



Ver. 2 March 2019









PRODUCT BULLETIN





BETA
industrial

index

>>	SAND TRAP LOUVERS - STL		01 - 02
>>	SAND TRAP LOUVERS - STLC		03 - 04
>>	2 INCH EXHAUST AIR LOUVERS - EAL - 2		05 - 06
>>	4 INCH EXHAUST AIR LOUVERS - EAL - 4		07 - 08
>>	GRAVITY AIR LOUVERS - GAL		09
>>	FRESH AIR LOUVERS - FAL / FALD		10
>>	FRESH AIR LOUVERS - HINGED FALH/FALHD		11
>>	ALUMINIUM FILTER AF		12



STL

>> The sand trap louver is made of aluminum section/ GI sheet. It is composed of two sets of inverted U-channels, mounted vertically on two opposite rows.

>> The sand trap louver is used at the fresh air inlet. It can lower the dust loading of conventional filtration as it is designed to separate large size sand particles at low to medium speeds. It can be fitted with a bird/insect screen mesh.

>> The sand trap louver is a self emptying system, it has a set of holes at the bottom of the casing to discharge separated sand particles.

>> Tested by AMCA in accordance with ANSI/ AMCA 500-L

SAND TRAP LOUVERS

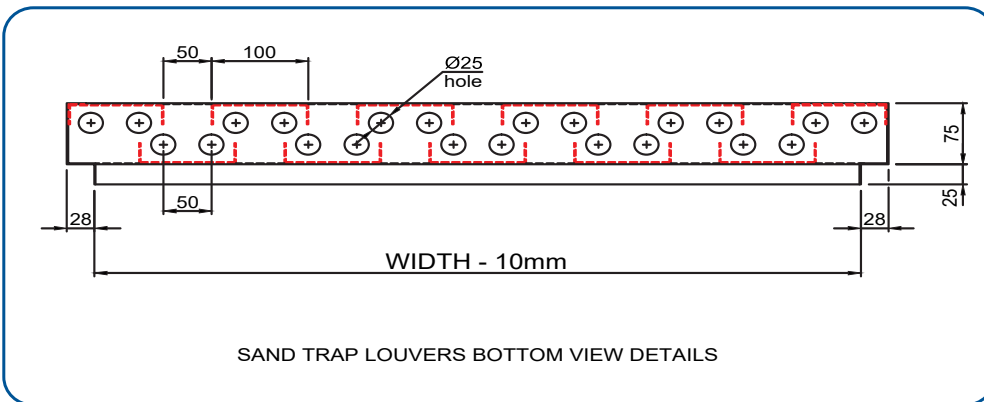
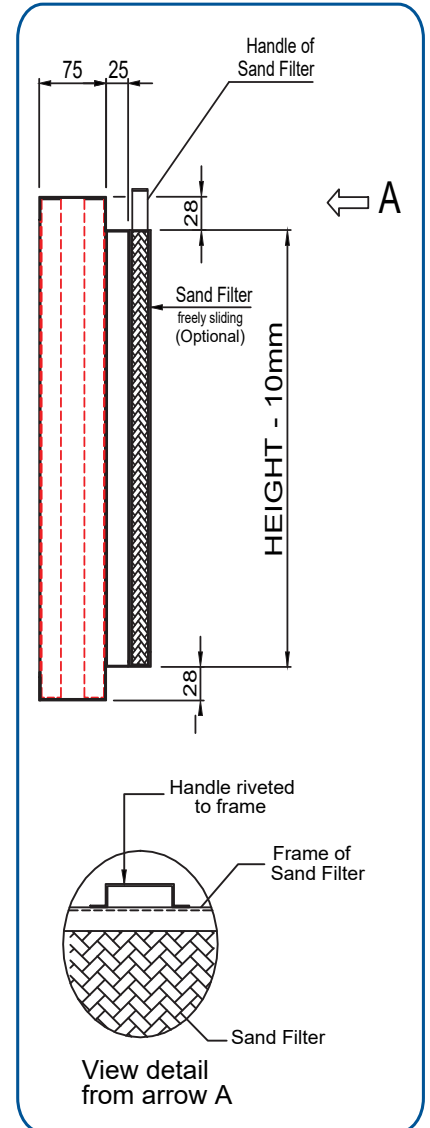
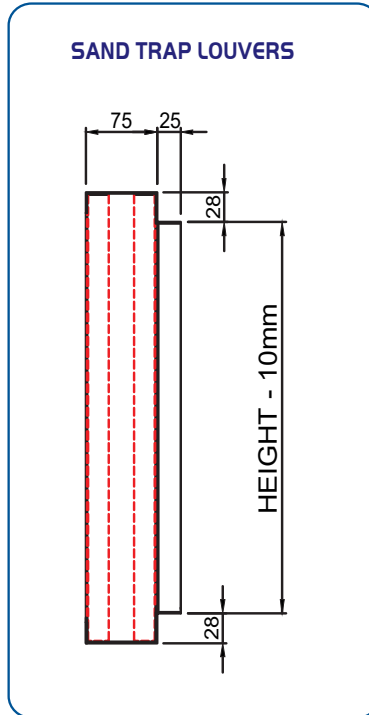

SAND TRAP LOUVERS BOTTOM VIEW DETAILS

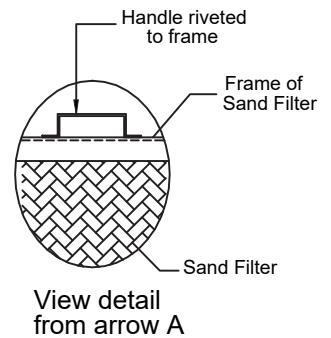

Ordering Key:

S	T	LA	SSWM	SF	SIZE
STLA: SAND TRAP LOUVER IN ALUMINIUM					
STLG: SAND TRAP LOUVER IN GI					
-: WITHOUT SCREEN/WIRE MESH					
IS: G.I. INSECT SCREEN					
SSWM: STAINLESS STEEL WIRE MESH					
-: WITHOUT FILTER					
SF: WITH SLIDING 1 INCH THICK ALUMINUM FILTER					
SF2: WITH SLIDING 2 INCH THICK ALUMINUM FILTER					
SIZE: WIDTH X HEIGHT					
**NOTE: 78 INCH X 78 INCH (OUT TO OUT) IS MAXIMUM SINGLE SECTION SIZE					





Beta Industrial LLC certifies that the STL shown hereon is licensed to bear the AMCA Seal. The ratings shown are based on tests and procedures performed in accordance with AMCA Publication 511 and comply with the requirements of the AMCA Certified Ratings Program.

The AMCA Certified Ratings Seal applies to Air Performance and Wind Driven Sand.

Test Information

Tested in accordance with ANSI/AMCA 500-L, Figure 5.5 Test sample size is 1219mm x 1219mm (48 in. x 48 in.) Air Performance data are based on exhaust performance

The sand grading used for the test is between 76µm - 699µm as per AMCA 500-L.

FREE AREA CHART (SQUARE FEET)

Width (inches)

Height (inches)	Width (inches)														Free Area velocity, m/s	Sand Rejection Louver Effectiveness (%)	Penetration Class
	Out to Out	12	18	24	30	36	42	48	54	60	66	72	78				
	Out to Out	Neck Size	9.8	15.8	21.8	27.8	33.8	39.8	45.8	51.8	57.8	63.8	69.8	75.8			
12	9.8	0.17	0.31	0.45	0.59	0.73	0.88	1.02	1.16	1.30	1.44	1.58	1.72	1.000	86.10	B	
18	15.8	0.28	0.51	0.73	0.96	1.18	1.41	1.64	1.86	2.09	2.32	2.54	2.77	2.500	58.96	D	
24	21.8	0.39	0.70	1.01	1.32	1.64	1.95	2.26	2.57	2.88	3.20	3.51	3.82	4.000	21.94	D	
30	27.8	0.48	0.89	1.29	1.69	2.09	2.48	2.88	3.28	3.68	4.08	4.47	4.87	5.500	10.96	D	
36	33.8	0.60	1.06	1.57	2.05	2.54	3.02	3.50	3.99	4.47	4.96	5.44	5.92	7.000	7.8	D	
42	39.8	0.71	1.28	1.85	2.42	2.99	3.56	4.13	4.70	5.27	5.84	6.41	6.98				
48	45.8	0.81	1.47	2.12	2.78	3.44	4.09	4.75	5.40	6.06	6.72	7.37	8.03				
54	51.8	0.92	1.66	2.40	3.14	3.89	4.63	5.37	6.11	6.85	7.60	8.34	9.08				
60	57.8	1.02	1.85	2.68	3.51	4.34	5.16	5.99	6.82	7.65	8.48	9.30	10.13				
66	63.8	1.13	2.04	2.96	3.87	4.79	5.70	6.61	7.53	8.44	9.36	10.27	11.18				
72	69.8	1.24	2.24	3.24	4.24	5.24	6.24	7.24	8.27	9.24	10.24	11.24	12.24				
78	75.8	1.34	2.43	3.51	4.60	5.69	6.77	7.86	8.94	10.03	11.12	12.20	13.29				

SAND REJECTION EFFECTIVENESS DATA

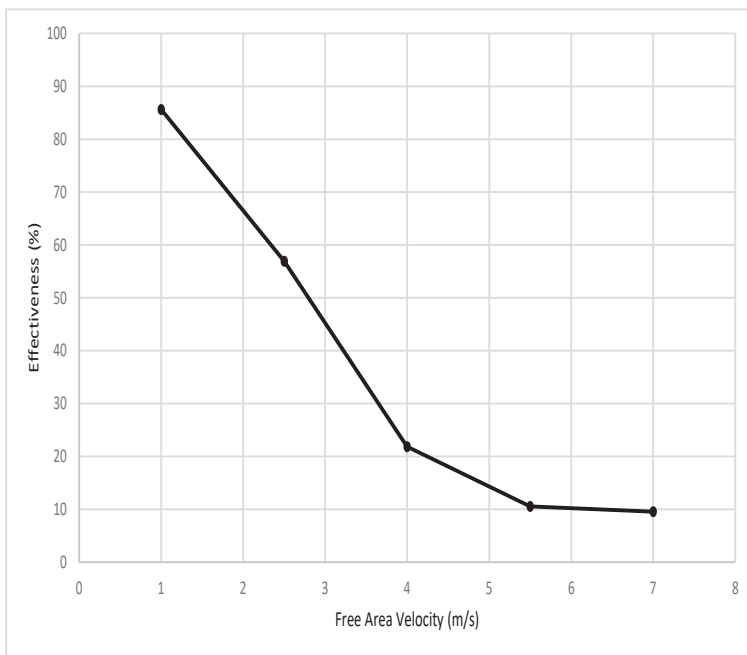

PRESSURE DROP DATA

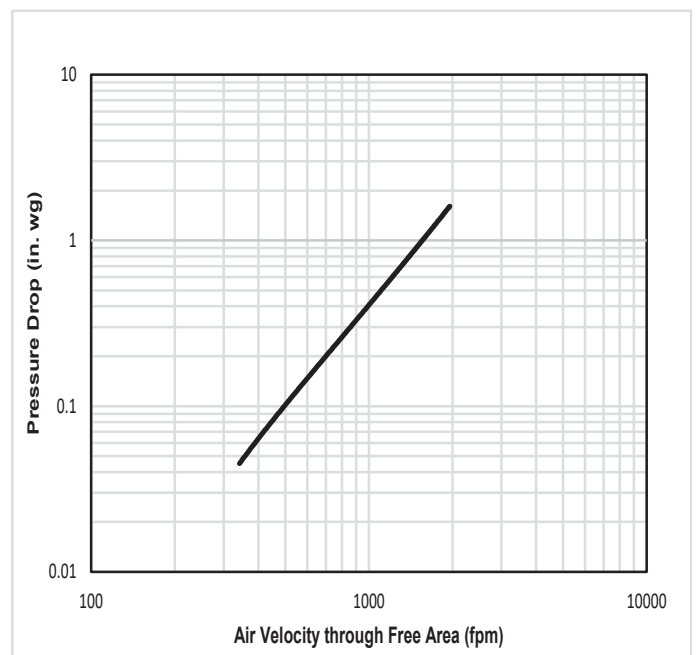



STLC

>> The sand trap louver is made of aluminum section/ GI sheet. It is composed of two sets of inverted U-channels, mounted vertically on two opposite rows.

>> The sand trap louver is used at the fresh air inlet duct. It can lower the dust loading of conventional filtration as it is designed to separate large size sand particles at low to medium speeds. It can be fitted with a bird/insect screen mesh.

>> The sand trap louver is a self emptying system, it has a set of holes at the bottom and a chute to discharge separated sand particles.

>> Tested by AMCA in accordance with ANSI/ AMCA 500-L

SAND TRAP LOUVERS WITH SAND CHUTE

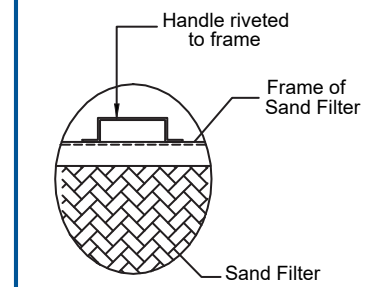
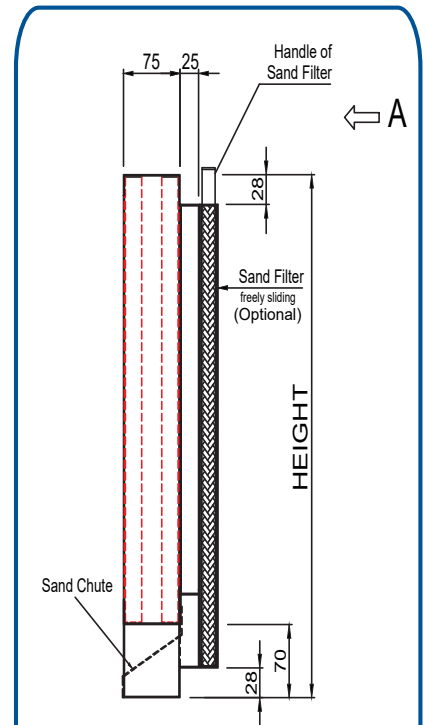
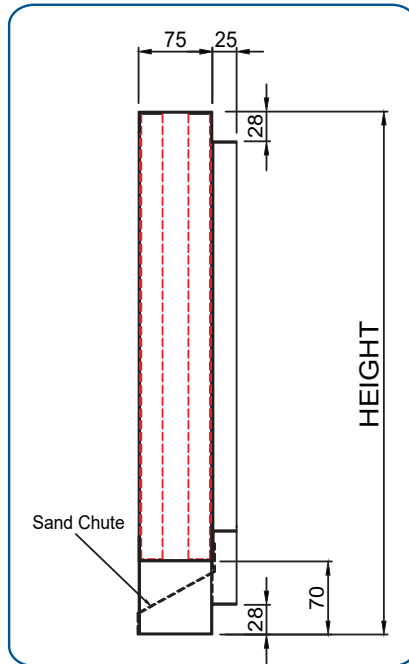

View detail from arrow A

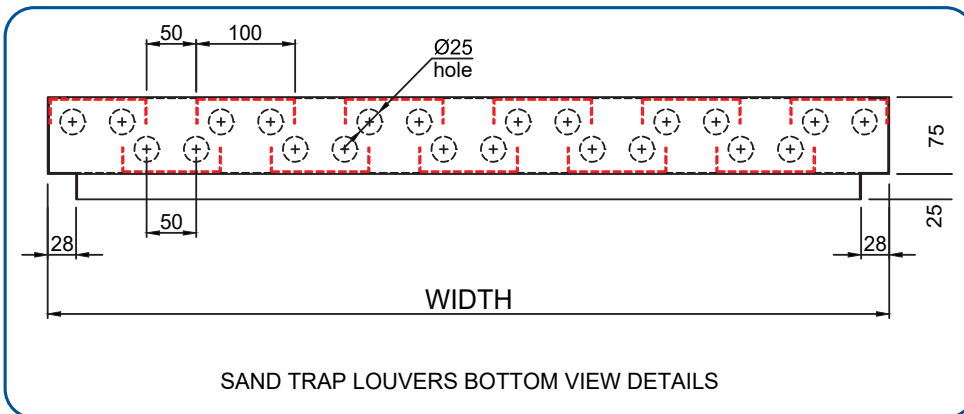

SAND TRAP LOUVERS BOTTOM VIEW DETAILS

Ordering Key:

S	T	L	CA	SSWM	SF	SIZE
STLCA: SAND TRAP LOUVER WITH CHUTE IN ALUMINIUM						
STLCG: SAND TRAP LOUVER WITH CHUTE IN GI						
-: WITHOUT SCREEN/WIRE MESH						
IS: G.I. INSECT SCREEN						
SSWM: STAINLESS STEEL WIRE MESH						
-: WITHOUT FILTER						
SF: WITH SLIDING 1 INCH THICK ALUMINIUM FILTER						
SF2: WITH SLIDING 2 INCH THICK ALUMINIUM FILTER						
SIZE: WIDTH X HEIGHT						
**NOTE: 78 INCH X 78 INCH (OUT TO OUT) IS MAXIMUM SINGLE SECTION SIZE						





Beta Industrial LLC certifies that the STLC shown hereon is licensed to bear the AMCA Seal. The ratings shown are based on tests and procedures performed in accordance with AMCA Publication 511 and comply with the requirements of the AMCA Certified Ratings Program.

The AMCA Certified Ratings Seal applies to Air Performance, Wind Driven Sand and Water Penetration.

The beginning point of water penetration is 232.6 fpm

Test Information

Tested in accordance with ANSI/AMCA 500-L, Figure 5.5 Test sample size is 1219mm x 1219mm (48 in. x 48 in.) Air Performance data are based on exhaust performance

The sand grading used for the test is between 76µm - 699µm as per AMCA 500-L.

PRESSURE DROP DATA

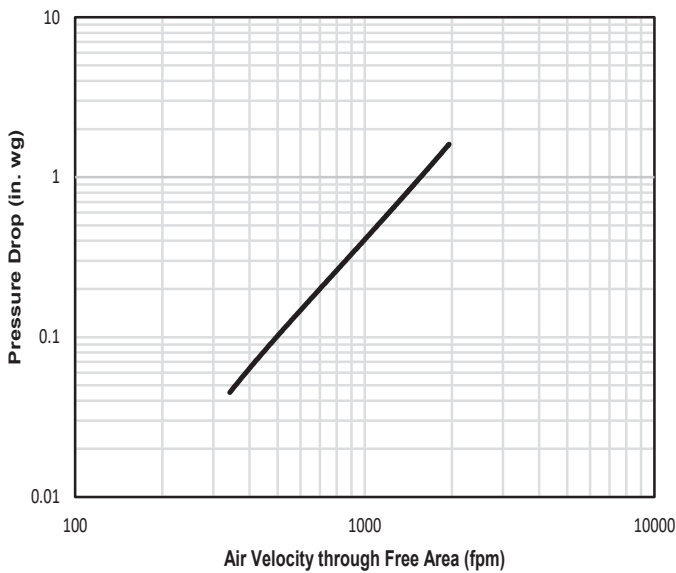

WATER PENETRATION DATA

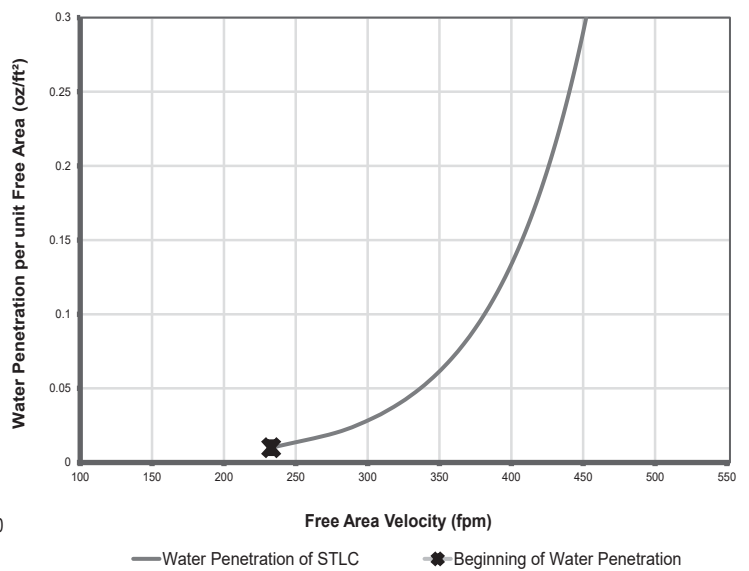

SAND REJECTION EFFECTIVENESS DATA

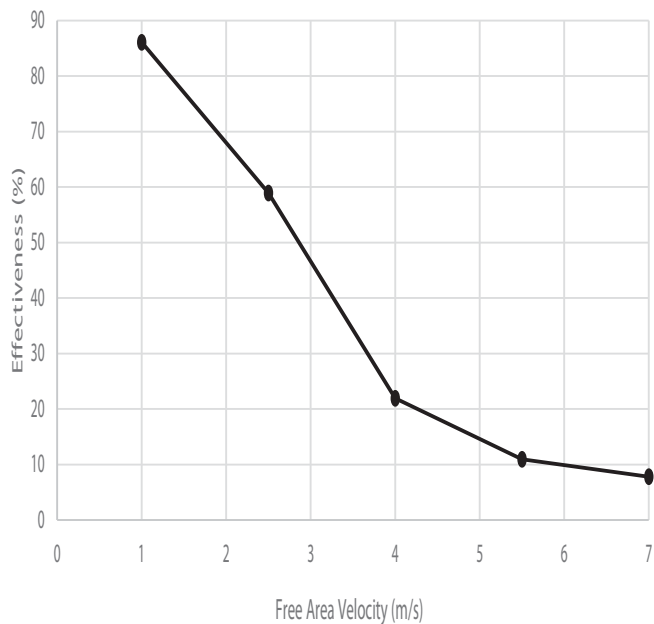

FREE AREA CHART (SQURE FEET)

Height (inches)	Width (inches)												
	Out to Out	12	18	24	30	36	42	48	54	60	66	72	78
12	9.8	0.13	0.23	0.34	0.44	0.54	0.65	0.75	0.85	0.96	1.06	1.16	1.27
18	15.8	0.23	0.42	0.61	0.80	0.99	1.18	1.37	1.56	1.75	1.94	2.13	2.32
24	21.8	0.34	0.62	0.89	1.17	1.44	1.72	1.99	2.27	2.55	2.82	3.10	3.37
30	27.8	0.45	0.81	1.17	1.53	1.89	2.25	2.62	2.98	3.34	3.70	4.06	4.42
36	33.8	0.55	1.00	1.45	1.90	2.34	2.79	3.24	3.69	4.13	4.58	5.03	5.48
42	39.8	0.66	1.19	1.73	2.26	2.79	3.33	3.86	4.39	4.93	5.46	5.99	6.53
48	45.8	0.77	1.39	2.00	2.62	3.24	3.86	4.48	5.10	5.72	6.34	6.96	7.58
54	51.8	0.87	1.58	2.28	2.99	3.70	4.40	5.10	5.81	6.52	7.22	7.93	8.63
60	57.8	0.98	1.77	2.56	3.35	4.14	4.94	5.73	6.52	7.31	8.10	8.89	9.68
66	63.8	1.08	1.96	2.84	3.72	4.59	5.47	6.35	7.23	8.10	8.98	9.86	10.74
72	69.8	1.19	2.15	3.12	4.08	5.05	6.01	6.97	7.93	8.90	9.86	10.82	11.79
78	75.8	1.30	2.35	3.40	4.45	5.49	6.54	7.59	8.64	9.69	10.74	11.79	12.84

Free Area velocity, m/s	Sand Rejection Louver Effectiveness (%)	Penetration Class
1.000	85.31	B
2.500	56.90	D
4.000	21.85	D
5.500	10.56	D
7.000	9.54	D





LOUVERS



>> The well mounted exhaust air louver EAL-2 is a weather proof external cover for air inlet and discharge openings.

>> The exhaust air louver EAL-2 is composed of a set of blades made of aluminum extruded profiles/ GI sheet arranged in horizontal rows and inclined downward to protect against rain water.

>> The exhaust air louver EAL-2 is used in cooling, heating and air ventilation applications.

>> Frame depth 45mm, spacing 35mm & blade angle 60°

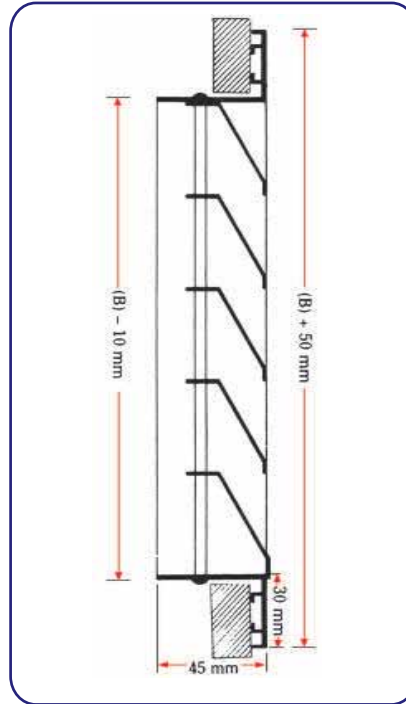

TYPE OF FIXING

Type of Fixing:
Screw fixing

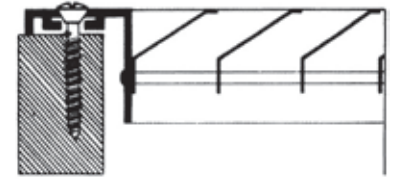

Clip Fixing

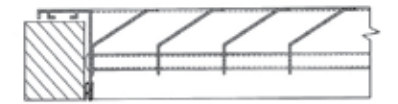

EXHAUST AIR LOUVER

FREE AREA CHART (SQUARE FEET)

		Width (inches)											
		12	18	24	30	36	42	48	54	60	66	72	78
Height (inches)	Out to Out	9.64	15.64	21.64	27.64	33.64	39.64	45.64	51.64	57.64	63.64	69.64	75.64
	Neck Size	0.17	0.29	0.41	0.52	0.64	0.76	0.88	0.99	1.11	1.23	1.35	1.46
	12	0.30	0.50	0.71	0.91	1.12	1.32	1.52	1.73	1.93	2.13	2.34	2.54
	18	0.43	0.72	1.01	1.30	1.59	1.88	2.17	2.46	2.75	3.04	3.33	3.62
	24	0.55	0.92	1.30	1.67	2.04	2.41	2.79	3.16	3.53	3.90	4.28	4.65
	30	0.08	1.14	1.00	2.00	2.51	2.97	3.43	3.89	4.35	4.81	5.27	5.73
	36	0.81	1.35	1.90	2.44	2.99	3.53	4.08	4.62	5.17	5.72	6.26	6.81
	42	0.62	1.55	2.17	2.80	3.42	4.05	4.67	5.30	5.92	6.55	7.17	7.80
	48	1.06	1.77	2.49	3.20	3.91	4.63	5.34	6.06	6.77	7.49	8.20	8.91
	54	1.18	1.99	2.79	3.59	4.39	5.19	5.99	6.79	7.59	8.39	9.19	9.99
	60	1.31	2.19	3.07	3.96	4.84	5.72	6.61	7.49	8.37	9.26	10.14	11.02
	66	1.43	2.40	3.37	4.34	5.31	6.28	7.25	8.22	9.19	10.16	11.13	12.10
	72	1.56	2.61	3.67	4.72	5.78	6.83	7.89	8.94	10.00	11.05	12.11	13.16
78													

Ordering Key:

E	A	L	2A	IS	SIZE
EAL2A: EXHAUST AIR LOUVER WITH 2 INCH DEPTH IN ALUMINIUM					
EAL2G: EXHAUST AIR LOUVER WITH 2 INCH DEPTH IN GI					
-: WITHOUT SCREEN/WIRE MESH					
IS: WITH G.I. INSECT SCREEN					
SSWM: WITH STAINLESS STEEL WIRE MESH					
SIZE: WIDTH X HEIGHT					
**NOTE: 78 INCH X 78 INCH (OUT TO OUT) IS MAXIMUM SINGLE SECTION SIZE					





Beta Industrial LLC certifies that the EAL2 shown hereon is licensed to bear the AMCA Seal. The ratings shown are based on tests and procedures performed in accordance with AMCA Publication 511 and comply with the requirements of the AMCA Certified Ratings Program.

The AMCA Certified Ratings Seal applies to Air Performance and Water Penetration ratings.

The beginning point of water penetration is 264.4 fpm

Test Information

Tested in accordance with ANSI/AMCA 500-L, Figure 5.5 Test sample size is 1219mm x 1219mm (48 in. x 48 in.) (Out to Out). Air Performance data are based on exhaust performance

PRESSURE DROP DATA

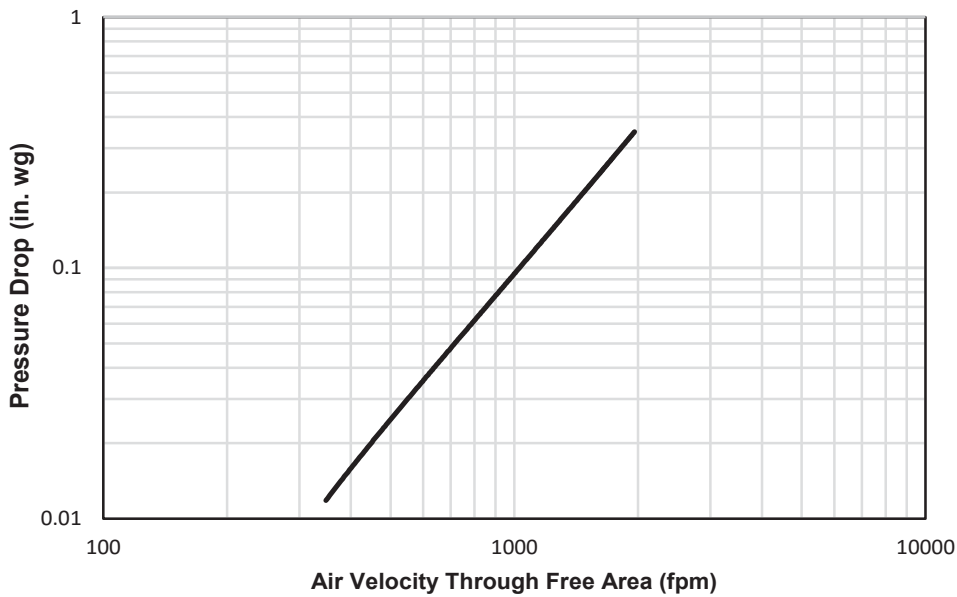

WATER PENETRATION DATA

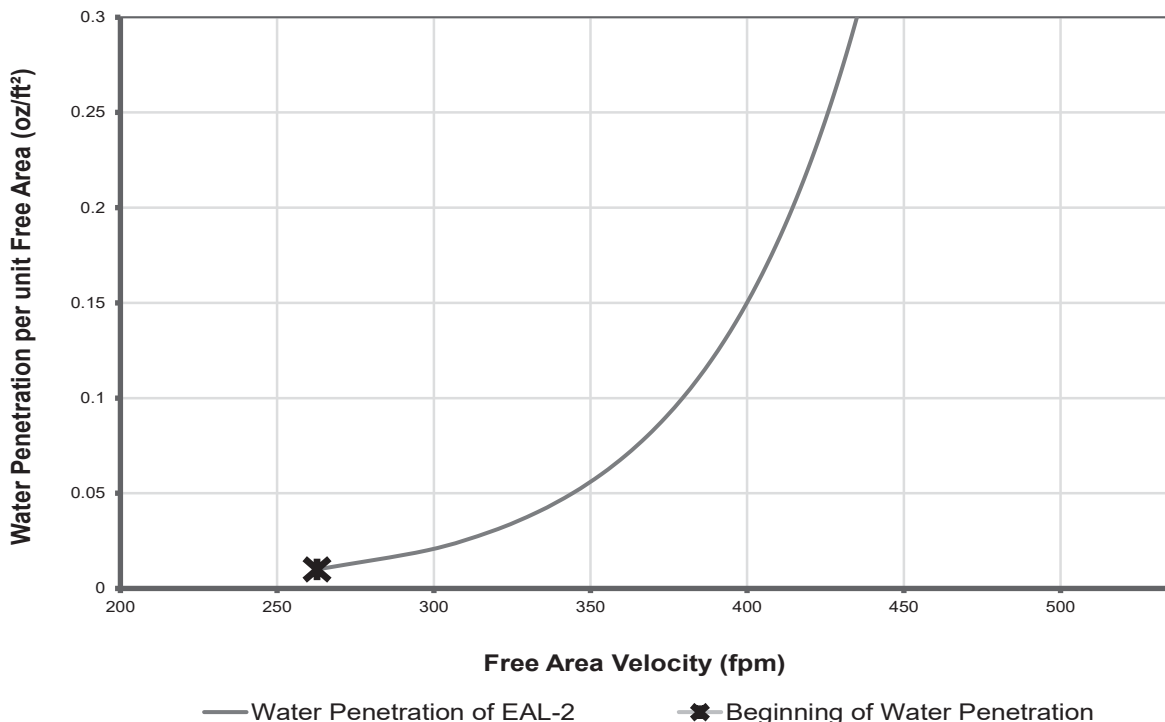

— Water Penetration of EAL-2 ✕ Beginning of Water Penetration





LOUVERS

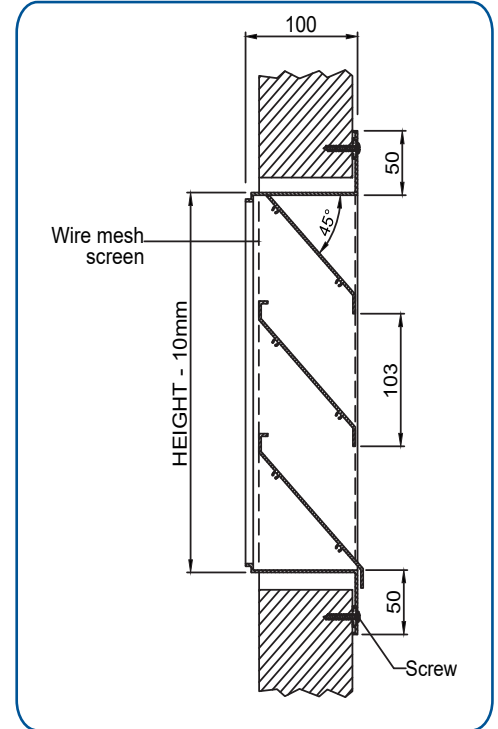
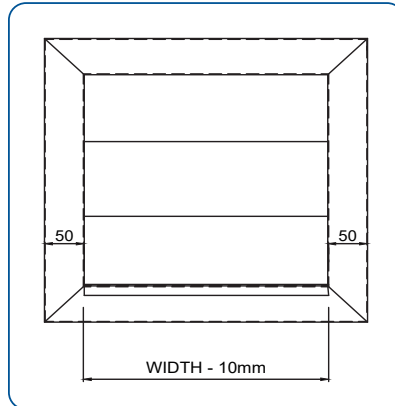

- >> The exhaust air louver is composed of a set of blades made of 2MM aluminum extruded profile/ GI sheet arranged in 45 degree in horizontal rows and inclined downward to protect against rain water.
- >> The exhaust air louver is used in cooling, heating and air ventilation applications for intake & discharge.
- >> Frame depth 100MM, spacing 87MM & blade angle 45.
- >> The wall mounted exhaust air louver EAL-4 is a weather proof external cover for air inlet and discharge openings.

FREE AREA CHART (SQUARE FEET)

		Width (inches)											
		12	18	24	30	36	42	48	54	60	66	72	78
Out to Out	Neck Size	8.06	14.06	20.06	26.06	32.06	38.06	44.06	50.06	56.06	62.06	68.06	74.06
12	8.06	0.18	0.32	0.46	0.60	0.75	0.89	1.03	1.17	1.32	1.46	1.60	1.75
18	14.06	0.35	0.64	0.92	1.21	1.50	1.78	2.07	2.35	2.64	2.92	3.21	3.50
24	20.06	0.71	1.28	1.85	2.42	2.99	3.56	4.13	4.70	5.27	5.85	6.42	6.99
30	26.06	0.88	1.6	2.31	3.02	3.74	4.45	5.17	5.88	6.60	7.31	8.02	8.73
36	32.06	1.23	2.23	3.23	4.22	5.22	6.22	7.21	8.21	9.21	10.20	11.20	12.19
42	35.06	1.41	2.56	3.70	4.84	5.98	7.12	8.26	9.41	10.55	11.69	12.83	13.97
48	44.06	1.76	3.17	4.59	6.01	7.43	8.84	10.26	11.68	13.10	14.52	15.93	17.35
54	50.06	1.94	3.51	5.08	6.65	8.22	9.79	11.36	12.93	14.50	16.07	17.64	19.21
60	56.06	2.28	4.12	5.96	7.79	9.63	11.47	13.31	15.15	16.99	18.83	20.67	22.51
66	62.06	2.48	4.47	6.47	8.47	10.47	12.47	14.46	16.46	18.46	20.46	22.46	24.45
72	68.06	2.8	5.06	7.32	9.58	11.84	14.10	16.36	18.62	20.88	23.14	25.40	27.66
78	74.06	3.00	4.43	7.86	10.28	12.71	15.14	17.56	19.99	22.42	24.84	27.27	29.69

Ordering Key:

E	A	L	4 A/G	IS	SIZE
EAL4A: EXHAUST AIR LOUVER WITH 4 INCH DEPTH IN ALUMINIUM EAL4G: EXHAUST AIR LOUVER WITH 4 INCH DEPTH IN GI					
-: WITHOUT SCREEN/WIRE MESH					
IS: WITH G.I. INSECT SCREEN SSWM: WITH STAINLESS STEEL WIRE MESH					
SIZE: WIDTH X HEIGHT (NECK SIZE)					
**NOTE: 78 INCH X 78 INCH (OUT TO OUT) IS MAXIMUM SINGLE SECTION SIZE					





Beta Industrial LLC certifies that the EAL4 shown hereon is licensed to bear the AMCA Seal. The ratings shown are based on tests and procedures performed in accordance with AMCA Publication 511 and comply with the requirements of the AMCA Certified Ratings Program.

The AMCA Certified Ratings Seal applies to Air Performance and Water Penetration ratings.

The beginning point of water penetration is 752.1 fpm

Test Information

Tested in accordance with ANSI/AMCA 500-L, Figure 5.5 Test sample size is 1219mm x 1219mm (48 in. x 48 in.) (Out to Out). Air Performance data are based on exhaust performance

PRESSURE DROP DATA

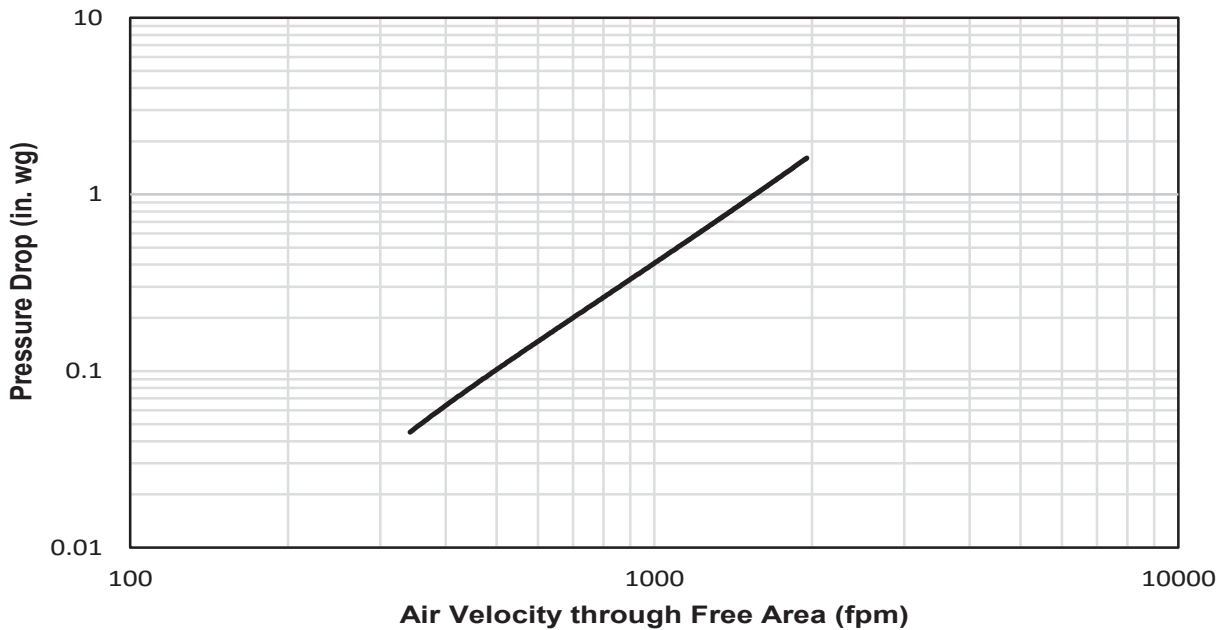

WATER PENETRATION DATA

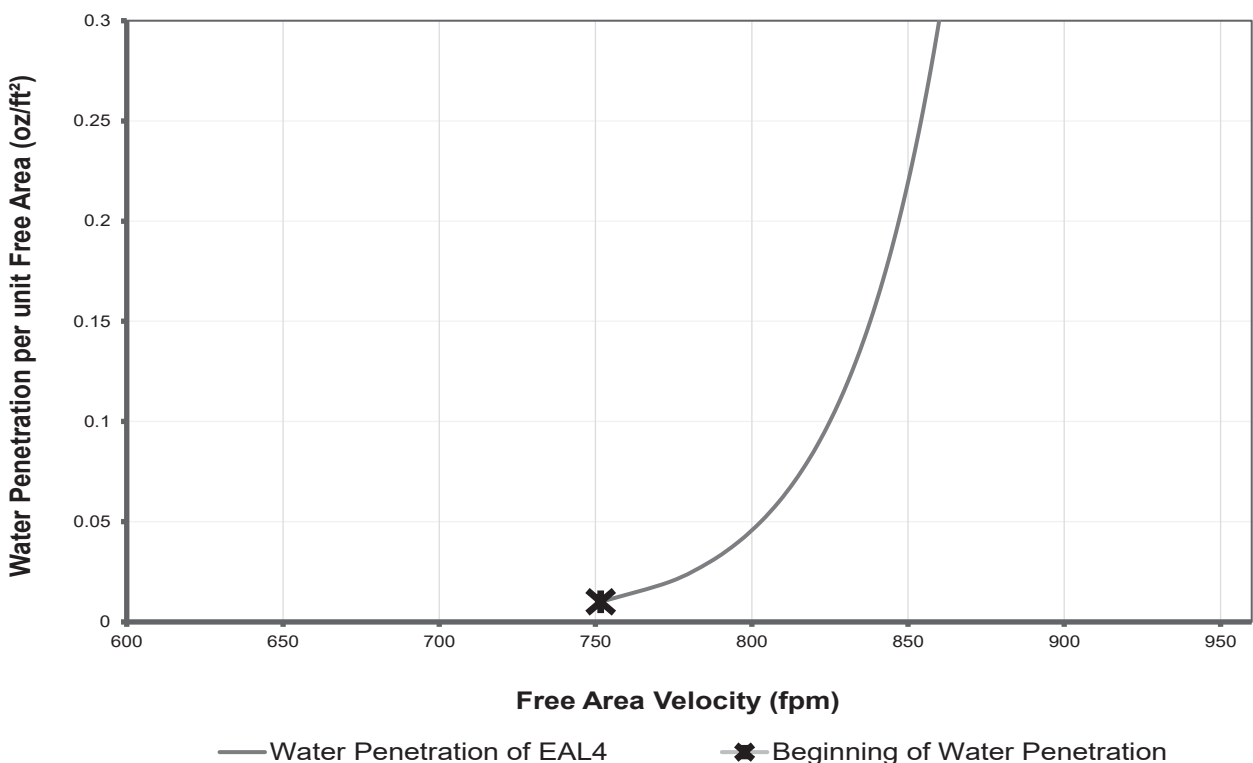

— Water Penetration of EAL4 ✕ Beginning of Water Penetration



LOUVERS



>> The gravity air louver is a wall mounted device. It is composed of a set of horizontally mounted blades; they are normally closed and are free to rotate about the horizontal axis.

>> The blades & frame are manufactured from aluminum extruded profiles.

>> Horizontally mounted blades are available with bushes.

>> Free area ratio (approx.) = 0.82 for 100% open blades.

>> To calculate the air flow rate :

$$CFM = \frac{0.82 \times A \text{ (in"} \times B \text{ (in"} \times \text{Face velocity (fpm)}}{144}$$

$$L/S = \frac{0.82 \times A \text{ (mm)} \times B \text{ (mm)} \times \text{Face velocity (m/s)}}{1000}$$

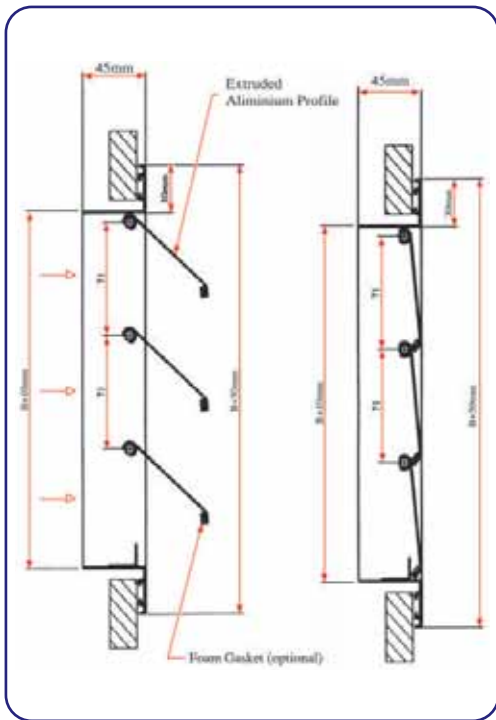

TYPE OF FIXING

SCREW FIXING

CLIP FIXING

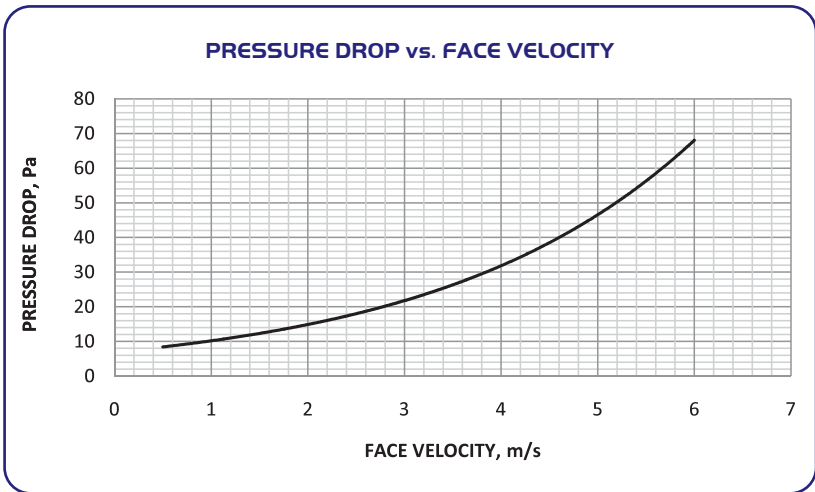
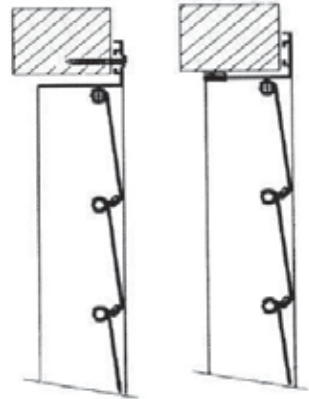

Ordering Key:

G	A	L	B	CR	SSWM	SIZE
GALB: GRAVITY AIR LOUVER WITH BRASS BUSHES						
GAL: GRAVITY AIR LOUVER WITHOUT BUSHES						
--: WITHOUT CONNECTING ROD ON BLADES						
CR: WITH CONNECTING ROD ON BLADES						
--: WITHOUT SCREEN/WIRE MESH						
IS: WITH G.I. INSECT SCREEN						
SSWM: WITH STAINLESS STEEL WIRE MESH						
SIZE: WIDTH X HEIGHT						
**NOTE: 2000 MM X 2000 MM IS MAXIMUM SINGLE SECTION SIZE						





>> The wall mounted fresh air louver is a simple form of filter louver. It is composed of an exhaust louver with an aluminum filter fixed at the back.

>> The fresh air louver is used to supply fresh clean air to the air handling units.

>> The filter is made from washable aluminum 1" media and is fixed on the back of the grille.

>> Insulating gasket can be fixed around the back of the frame to prevent infiltration between the frame and the wall.

Available types of finishing:

>> Natural anodized aluminum finish.

>> Powder coated to RAL codes.

>> Free area ratio (approx.) = 0.37

>> To calculate the air flow rate :

$$CFM = \frac{0.37 \times A \text{ (in"}^2) \times B \text{ (in"}^2) \times \text{Face velocity (fpm)}}{144}$$

$$L/S = \frac{0.37 \times A \text{ (mm)} \times B \text{ (mm)} \times \text{Face velocity (m/s)}}{1000}$$

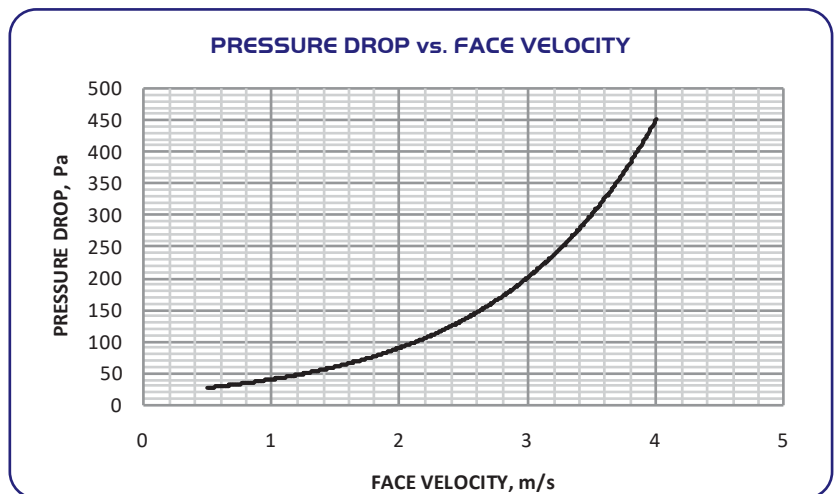
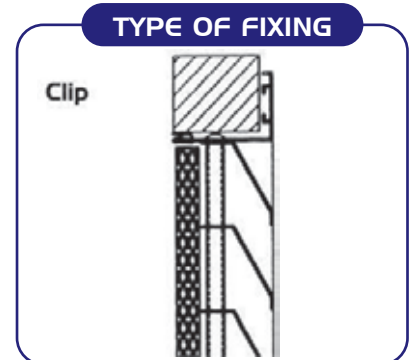
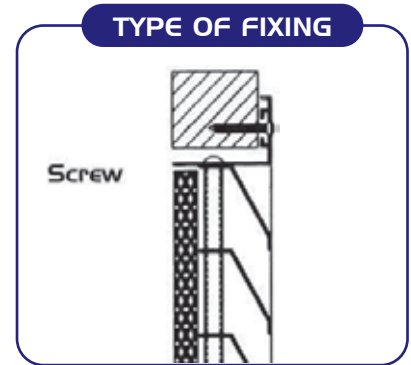
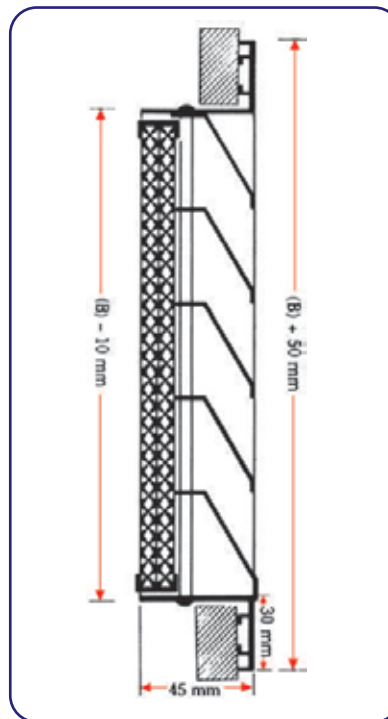

Ordering Key:

F	A	L	DB	SIZE
FRESH AIR LOUVER (WITH 1" AL FILTER)				
-: WITHOUT DAMPER				
DB: WITH BLACK DAMPER				
DM: WITH MILL FINISH DAMPER				
SIZE: WIDTH X HEIGHT				
**NOTE: 2000 MM X 2000 MM IS MAXIMUM SINGLE SECTION SIZE				





LOUVERS



>> The wall-mounted fresh air louver is composed of an exhaust air louver which is fixed to a frame that contains a filter by means of steel hinges.

>> The filter is made of washable aluminum media. It is contained in rear frame and is easily removable.

>> The fresh air louver can be opened like door to give flexibility to access the filter for either cleaning or changing.

>> The fresh air louver is used in cooling, heating and ventilation application. The existence of filter provides clean air to the system.

>> Free area ratio (approx.) = 0.37

>> To calculate the air flow rate :

$$CFM = \frac{0.37 \times A \text{ (in"} \text{)} \times B \text{ (in"} \text{)} \times \text{Face velocity (fpm)}}{144}$$

$$L/S = \frac{0.37 \times A \text{ (mm)} \times B \text{ (mm)} \times \text{Face velocity (m/s)}}{1000}$$

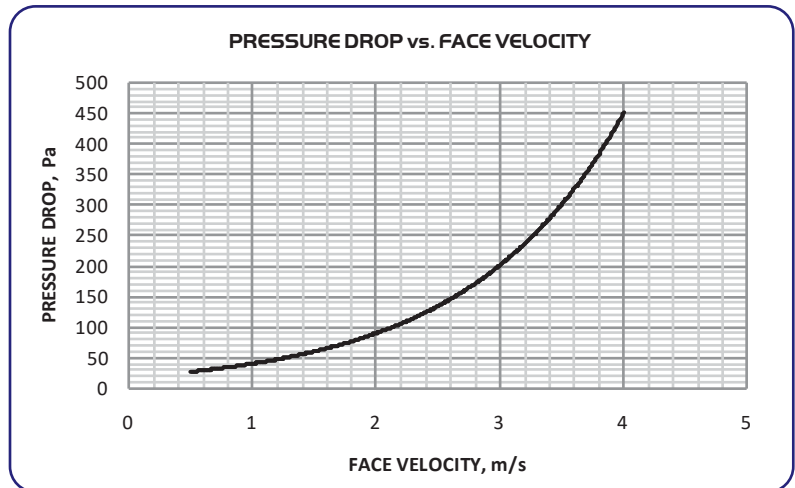
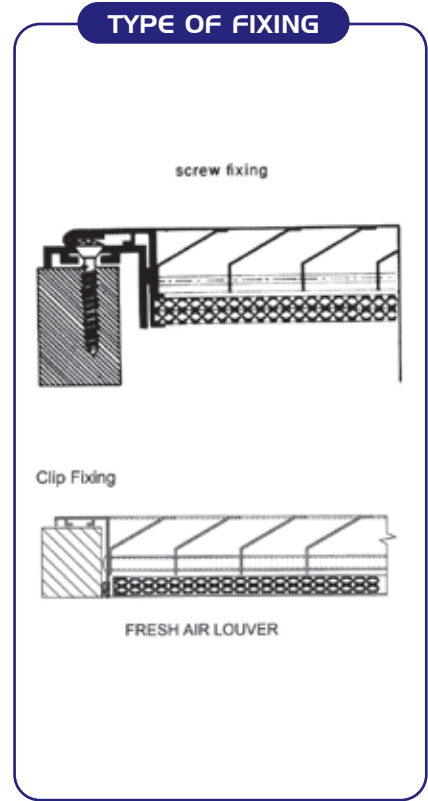
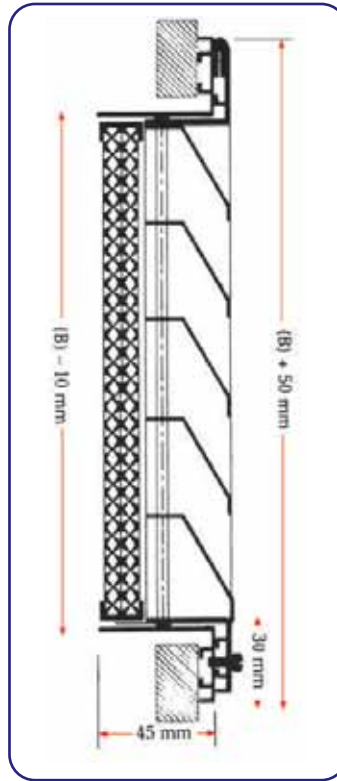

Ordering Key:

F	A	L	H	DB	SIZE
HINGED FRESH AIR LOUVER (WITH 1" AL FILTER)					
-: WITHOUT DAMPER					
DB: WITH BLACK DAMPER					
DM: WITH MILL FINISH DAMPER					
SIZE: WIDTH X HEIGHT					
**NOTE: 2000 MM X 2000 MM IS MAXIMUM SINGLE SECTION SIZE					





- >> AF Aluminum Filters are used widely in HVAC & other applications to filter air from dust and dirt.
- >> AF is made of Aluminum filter media and a frame made of Aluminum extruded profiles.
- >> AF is easily washable for frequent long-life use.
- >> AF has a reasonable initial pressure drop

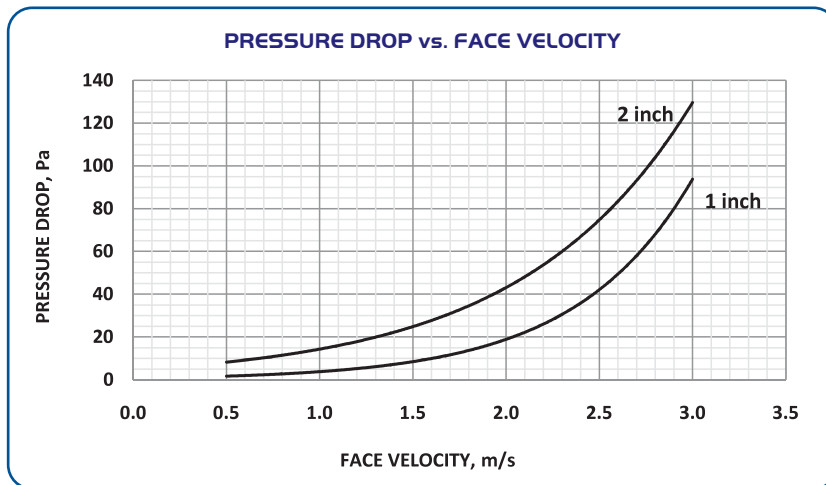
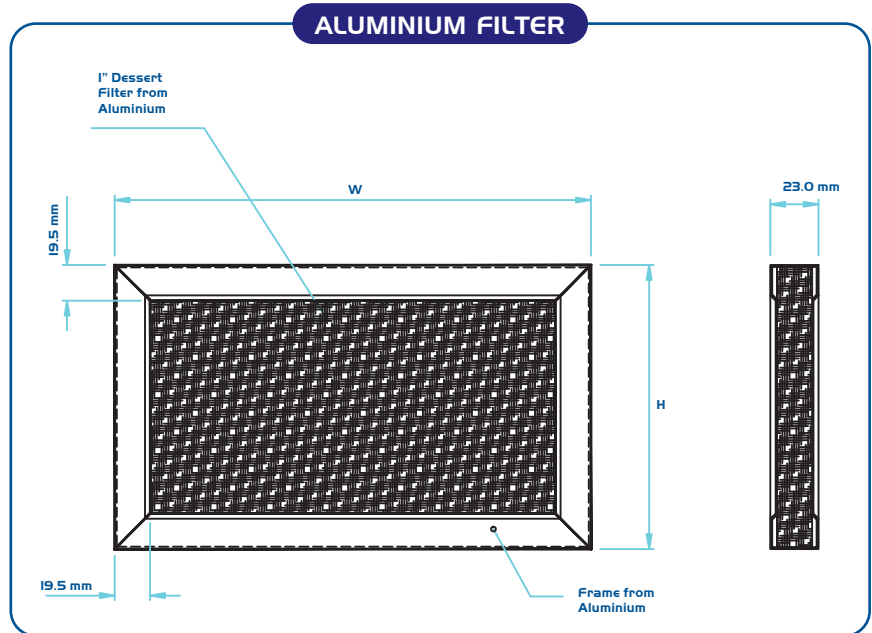

Ordering Key:

A	F	2	SIZE
ALUMINUM FILTER			
-: 1" THICK AL FILTER			
2: 2" THICK AL FILTER			
SIZE: WIDTH X HEIGHT			





NOTES :

A series of horizontal dashed red lines for writing notes.





NOTES :

A series of horizontal dashed red lines for writing notes.





BETA
industrial

Dubai Head Office:
Tel: +971 4 706 9777
Fax: +971 4 706 9787

Abu Dhabi Branch:
Tel: +971 2 645 0107
Fax: +971 2 645 0167

Saudi Arabia:
Tel: +966 1 265 4551
Fax: +966 1 265 4550

Email: betai@betag.com
P.O.Box 50708, Dubai
United Arab Emirates

www.betag.com

