



PRESSURE INDEPENDENT SINGLE DUCT VAV - SDV/SDVE MODELS

DESCRIPTION

SDV model

- Casing is made of 0.9mm & damper blade is made of 1.2mm; galvanized steel sheet.
- Damper shaft is made of solid square 1/2X1/2 inch G.I.
- With self-lubricating plastic bushes.
- Lined with 1/2 inch thick clean high efficient insulation made of strong resilient dual density glass fibers 24kg/m³ that conform to NFPA-90A & 255, UL 181 and ASTM C665.
- Insulation edges are covered by metal to prevent exposing to airstream for zero fiber migration.
- Equipped with a multi-point flow-cross inlet flow sensor made of Aluminum. Other types of sensors can be arranged upon request with minimum quantities applicable.
- Sound and Pressure Drop of SDV terminals are tested at Intertek - USA in accordance with industry standards AHRI 880-2017 and ASHRAE 130-2016.
- For both Variable Air Volume (VAV) and Constant Air Volume (CAV) applications.
- SDVE model is enabled for electric heater for re-heat application by extended length of box.

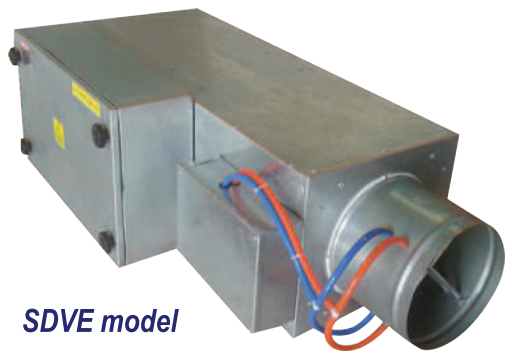

SDVE model

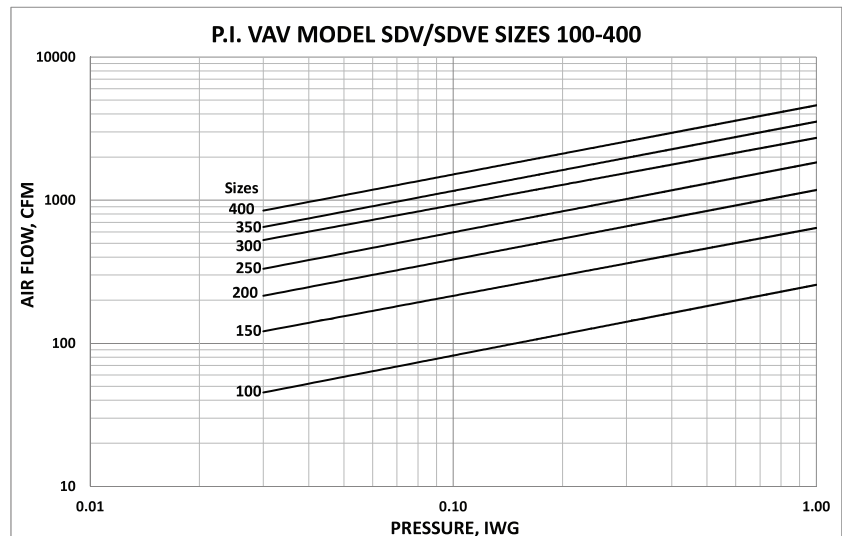

AIR CAPACITIES

SIZE	100	150	200	250	300	350	400
INLET DIA., IN	4	6	8	10	12	14	16
INLET AREA, SQ.FT.	0.09	0.20	0.35	0.55	0.79	1.07	1.40
NOMINAL FLOW, CFM	256	639	1176	1833	2721	3534	4597
MIN SENSIBLE FLOW, CFM	45	121	215	331	473	650	848





PRESSURE INDEPENDENT SINGLE DUCT VAV - SDV/SDVE MODELS

DIMENSIONS

1) SDV MODEL:

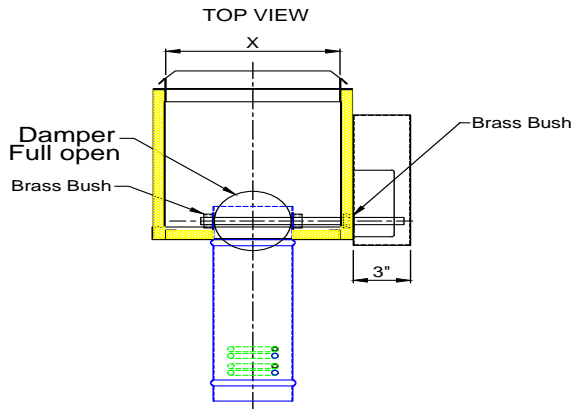

UNIT SIZE	DIMENSIONS							
	Width (total)	W	H	L	A	I	X	Y
4	13 (330)	10 (254)	10 (254)	11 (280)	10.5 (267)	3.875 (98)	8.75 (222)	8.75 (222)
6	13 (330)	10 (254)	10 (254)	11 (280)	6.5 (165)	5.875 (149)	8.75 (222)	8.75 (222)
8	15 (381)	12 (305)	10 (254)	11 (280)	6.5 (165)	7.875 (200)	10.75 (273)	8.75 (222)
10	17 (432)	14 (356)	12.5 (318)	13.25 (336)	6.5 (165)	9.875 (251)	12.75 (324)	11.25 (286)
12	19 (482)	16 (406)	15 (381)	13.25 (336)	6.5 (165)	11.875 (302)	14.75 (375)	13.25 (349)
14	23 (584)	20 (508)	17.5 (445)	17.5 (445)	6.5 (165)	13.875 (352)	18.75 (476)	16.25 (413)
16	27 (686)	24 (610)	17.5 (445)	17.5 (445)	6.5 (165)	15.875 (403)	22.75 (578)	16.25 (413)

NOTES:-
 • ALL DIMENSIONS ARE IN INCHES(MM) WITH A TOLLERANCE OF ±0.125"(3MM)

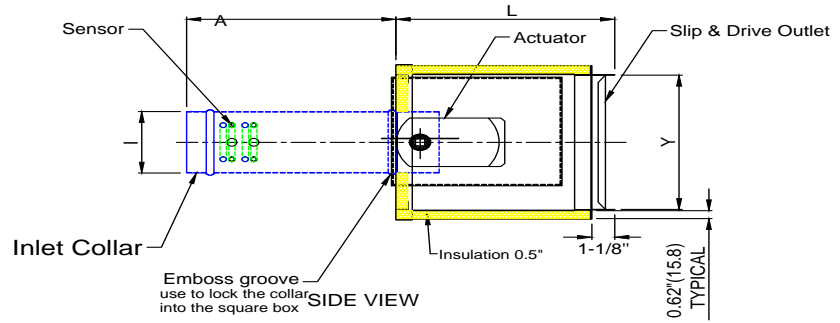
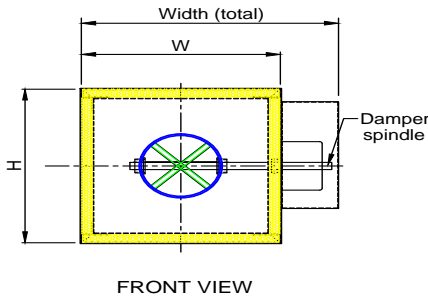

2) SDVE MODEL:

Note: "L" dimension shown and the dimensions of the control box of the electric heater are changeable according to size / capacity of the heating element and the options selected.

UNIT SIZE	DIMENSIONS							
	Width (total)	W	H	L	A	I	X	Y
4	13 (330)	10 (254)	10 (254)	35.5 (895)	10.5 (267)	3.875 (98)	8.75 (222)	8.75 (222)
6	13 (330)	10 (254)	10 (254)	35.5 (895)	6.5 (165)	5.875 (149)	8.75 (222)	8.75 (222)
8	15 (381)	12 (305)	10 (254)	35.5 (895)	6.5 (165)	7.875 (200)	10.75 (273)	8.75 (222)
10	17 (432)	14 (356)	12.5 (318)	32.25 (819)	6.5 (165)	9.875 (251)	12.75 (324)	11.25 (286)
12	19 (482)	16 (406)	15 (381)	32.25 (819)	6.5 (165)	11.875 (302)	14.75 (375)	13.25 (349)
14	23 (584)	20 (508)	17.5 (445)	32.25 (819)	6.5 (165)	13.875 (352)	18.75 (476)	16.25 (413)
16	27 (686)	24 (610)	17.5 (445)	32.25 (819)	6.5 (165)	15.875 (403)	22.75 (578)	16.25 (413)

NOTES:-
 • ALL DIMENSIONS ARE IN INCHES(MM) WITH A TOLLERANCE OF ±0.125"(3MM)

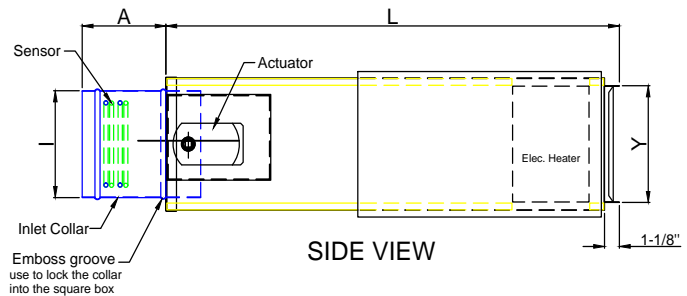
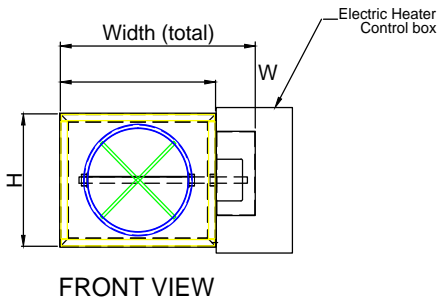
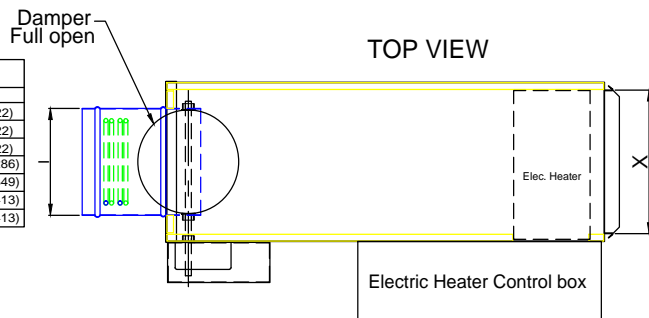



PRESSURE INDEPENDENT SINGLE DUCT VAV - SDV/SDVE MODELS

PERFORMANCE DATA

AHRI Certified Radiated Sound Power, $\Delta P_s = 1.5$ in.w.g

Terminal Size	Min Ps	CFM	Octave Band					
			125 Hz	250 Hz	500 Hz	1000 Hz	2000 Hz	4000 Hz
100	0.17	150	52	48	48	42	37	37
150	0.07	400	61	56	50	45	37	31
200	0.01	700	62	61	55	48	42	37
250	0.00	1100	58	55	56	46	37	30
300	0.00	1600	63	60	53	47	41	35
350	0.00	2100	63	62	54	47	41	35
400	0.05	2800	69	63	56	49	45	39

AHRI Certified Discharged Sound Power, $P_s = 1.5$ in.w.g

Terminal Size	Min Ps	CFM	Octave Band					
			125 Hz	250 Hz	500 Hz	1000 Hz	2000 Hz	4000 Hz
100	0.17	150	64	65	59	51	48	47
150	0.07	400	74	73	68	64	62	57
200	0.01	700	70	73	66	62	60	57
250	0.00	1100	74	72	65	63	62	59
300	0.00	1600	74	70	63	61	60	59
350	0.00	2100	76	75	66	65	64	61
400	0.05	2800	77	71	67	63	62	61

CERTIFICATIONS AND STANDARDS

- Units tested as per ASHRAE Standard 130-2016
- Model sizes certified in accordance with AHRI 880-2017 certification program.
- Radiated Sound Power Level Test is done in accordance with AHRI Standard 880-2017 and Figure 20 of ASHRAE 130-2016
- Discharge Sound Power Level Test is done in accordance with AHRI Standard 880-2017 and Figure 14 of ASHRAE 130-2016





PRESSURE INDEPENDENT SINGLE DUCT VAV - SDV/SDVE MODELS

PERFORMANCE DATA

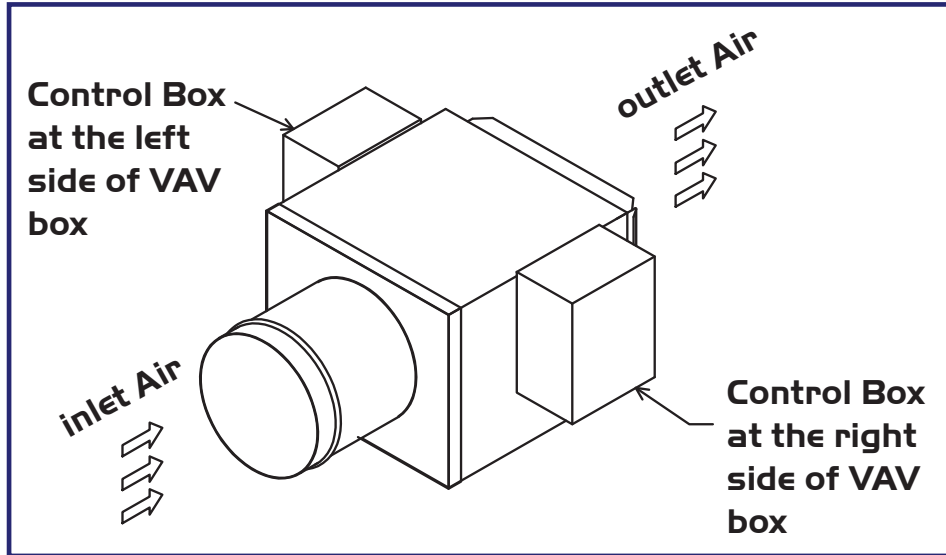

ORDERING KEY

Ordering Key:



S	D	V	E	2	5	0	L	B	S	T
PRESSURE INDEPENDENT TYPE SINGLE DUCT VAV BOX										
--: NOT ENABLED FOR ELECTRIC HEATER										
E: ENABLED FOR ELECTRIC HEATER										
SIZE: 100, 150, 200, 250, 300, 350 & 400										
L: CONTROL BOX AT LEFT OF VAV BOX (STANDARD)										
R: CONTROL BOX AT RIGHT OF VAV BOX										
ACTUATOR:										
B: BELIMO										
G: GRUNER										
H: HONEYWELL										
J: JOHNSON										
S: SIEMENS										
O: OTHER BRAND										
W: WITHOUT ACTUATOR										
THERMOSTAT:										
A: ACSYS										
B: BELIMO										
H: HONEYWELL										
J: JOHNSON										
S: SIEMENS										
T: TITAN										
O: OTHER BRAND										
W: WITHOUT THERMOSTAT										
T: WITH TRANSFORMER										
--: WITHOUT TRANSFORMER										

